

# Pulse + Bus Motion Controller

## ZMC432-V2

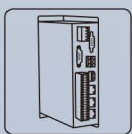

Vision Motion  
Controller

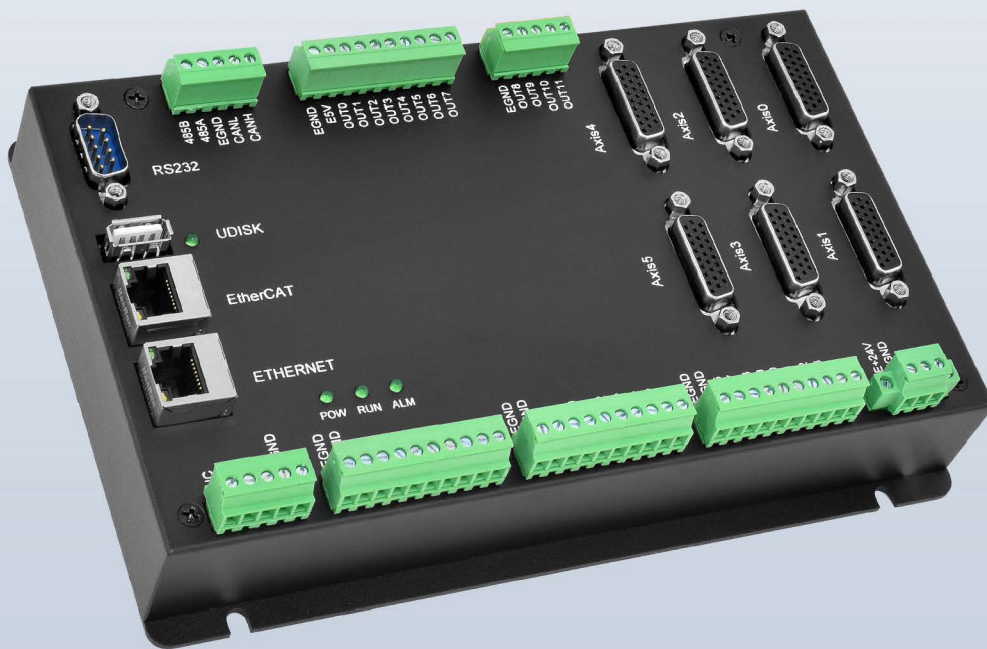
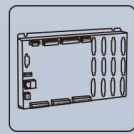

Motion  
Controller

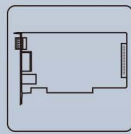

Motion Control  
Card

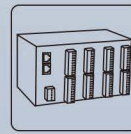

IO Expansion  
Module

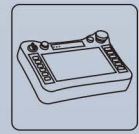

HMI



## Foreword

# Zmotion<sup>®</sup>

The motion controller provides rich interface, and it has excellent motion control performance, which can meet the expansion requirements of various projects.

This manual is copyrighted by Shenzhen Technology Co., Ltd., without the written permission of the Zmotion Technology, no person shall reproduce, translate and copy any content in this manual. The above-mentioned actions will constitute an infringement of the copyright of the company's manual, and Zmotion will investigate legal responsibility according to law.

For details about the ZMC controller software and the introduction and routine of each command, please refer to the ZBASIC software manual.

Information contained in this manual is only for reference. Due to improvements in design and functions and other aspects, Zmotion Technology reserves the final interpretation! Subject to change without notice!

**Pay attention to safety when debugging the machine!**

**Please be sure to design an effective safety protection device in the machine, and add an error handling program in the software, otherwise Zmotion has no obligation or responsibility for the loss caused.**

In order to ensure the safe, normal and effective use of the product, please be sure to read this product manual carefully before installing and using the product.



## Safety Statement

- This chapter describes the safety precautions required for the correct use of this product. Before using this product, please read the instructions for use and correctly understand the relevant information on safety precautions.
- This product should be used in an environment that meets the design specifications, otherwise it may cause equipment damage or personal injury, and malfunctions or component damage caused by failure to comply with relevant regulations are not within the scope of product quality assurance.
- Zmotion will not take any legal responsibility for personal safety accidents and property losses caused by failure to comply with the contents of this manual or illegal operation of products.

## Safety Level Definition

According to the level, it can be divided into " **Danger** " and " **Caution** ". Failure to operate as required may result in moderate injury, minor injury or equipment damage.

Please keep this guide in a safe place for reading when needed, and be sure to hand this manual to the end user.

Install	
 <b>Danger</b>	<ul style="list-style-type: none"><li>◆ When the controller is disassembled, all external power supplies used by the system should be disconnected before operation, otherwise it may cause misoperation or damage to the equipment.</li><li>◆ It is forbidden to use in the following places: places with dust, oil fume, conductive dust, corrosive gas and flammable gas; places exposed to high temperature, condensation, wind and rain; places with vibration and shock. Electric shock, fire and misuse can cause product damage and deterioration.</li></ul>
 <b>Notice</b>	<ul style="list-style-type: none"><li>◆ Avoid metal shavings and wire ends falling into the hardware circuit board during installation.</li><li>◆ After installation, ensure that there are no foreign objects on the hardware circuit board.</li><li>◆ When installing, make it tightly and firmly with the mounting frame.</li></ul>

	<ul style="list-style-type: none"> <li>◆ Improper installation of the controller may result in misoperation, failure and fire.</li> </ul>
<b>Wiring</b>	
 <p><b>Danger</b></p>	<ul style="list-style-type: none"> <li>◆ The specifications and installation methods of the external wiring of the equipment shall comply with the requirements of local power distribution regulations.</li> <li>◆ When wiring, all external power supplies used by the system should be disconnected before operation.</li> <li>◆ When powering on and running after the wiring work is completed, the terminals attached to the product must be installed.</li> <li>◆ Cable terminals should be well insulated to ensure that the insulation distance between cables will not be reduced after the cables are installed on the terminal block.</li> </ul>
 <p><b>Notice</b></p>	<ul style="list-style-type: none"> <li>◆ Avoid metal shavings and wire ends falling into the hardware circuit board during installation.</li> <li>◆ The cable connection should be carried out correctly on the basis of confirming the type of the connected interface.</li> <li>◆ It should be confirmed that the cables pressed into the terminals are in good contact.</li> <li>◆ Do not bundle the control wires and communication cables with the main circuit or power supply wires, etc., and the distance between the wires should be more than 100 mm, otherwise noise may cause malfunction.</li> <li>◆ If the controller is not installed properly, it may cause electric shock or equipment failure or malfunction.</li> </ul>

# Content

Chapter I Production Information.....	3
1.1. Product Information.....	3
1.2. Function Features.....	3
1.3. System Frame .....	4
1.4. Hardware Installment.....	5
Chapter II Product Specification .....	7
2.1. Basic Specification.....	7
2.2. Order Information .....	8
2.3. Interface Definition.....	9
2.4. Work Environment .....	10
Chapter III Wiring, Communication Configuration .....	12
3.1. Power Input .....	12
3.1.1. Power Specification.....	12
3.2. RS485, CAN Communication Interface.....	13
3.2.1. RS485, CAN Communication Specification & Wiring.....	13
3.2.2. Basic Usage Method .....	15
3.3. RS232 Serial Port .....	17
3.3.1. RS232 Communication Interface Specification & Wiring .....	17
3.3.2. Basic Usage.....	18
3.4. IN Digital Input & High-Speed Latch Port.....	19
3.4.1. Digital Input Specification & Wiring .....	21
3.4.2. Basic Usage Method .....	22
3.5. OUT (Digital Output, PWM Terminal, Hardware Comparison Output) .....	23
3.5.1. Digital Output Specification & Wiring.....	24
3.5.2. Basic Usage Method .....	27
3.6. Analog Output.....	28

---

3.6.1.	Analog Output Specification & Wiring .....	28
3.6.2.	Basic Usage Method .....	29
3.7.	U Disk .....	30
3.8.	ETHERNET .....	30
3.9.	EtherCAT Bus Interface .....	32
3.10.	AXIS Differential Pulse Axis Interface .....	33
3.10.1.	AXIS Interface Signal Specification & Wiring.....	35
3.10.2.	Basic Usage Method .....	39
Chapter IV	Expansion Module .....	41
4.1.	CAN Bus Expansion.....	41
4.1.1.	CAN Bus Expansion Wiring.....	41
4.1.2.	CAN Bus Expansion Resource Mapping .....	43
4.2.	EtherCAT Bus Expansion.....	47
4.2.1.	EtherCAT Bus Expansion Wiring.....	47
4.2.2.	EtherCAT Bus Expansion Resource Mapping .....	48
Chapter V	Program & Applications.....	51
5.1.	ZDevelop Software Usage.....	51
5.2.	PC Upper-Computer Program Application .....	56
Chapter VI	Run and Maintain .....	59
6.1.	Regular Inspection and Maintenance .....	59
6.2.	Common Problems.....	60

# Chapter I Production Information

## 1.1. Product Information

ZMC is the abbreviation of the motion controller model launched by Zmotion Technology.

ZMC4 series support Zmotion XPLC function, and they can do configuration display through the network.

ZMC432-V2 high-performance multi-axis motion controller is a stand-alone motion controller that is compatible with EtherCAT bus and pulse type. The controller itself supports 32 axes at most to achieve complex continuous trajectory control requirements.

ZMC4 series high-performance multi-axis motion controllers can be applied in robots (SCARA, Delta, 6 joints), electronic semiconductor equipment (testing equipment, assembly equipment, locking equipment, soldering machine), dispensing equipment, non-standard equipment, printing and packaging equipment, textile and garment equipment, stage entertainment equipment, medical equipment, assembly line, etc.

## 1.2. Function Features

- ◆ 32 axes motion control at most.
- ◆ Pulse output mode: pulse / direction or dual pulses or quadrature pulse.
- ◆ Maximum pulse output frequency of each axis is 10MHZ.
- ◆ 4096 isolated inputs and 4096 isolated outputs can be extended through ZCAN and EtherCAT.
- ◆ Axis position limit signal / origin signal port can be configured as any input at will.
- ◆ The maximum output current of general digital outputs can reach 300mA, which can

directly drive some kinds of solenoid valves.

- ◆ Interfaces: EtherCAT, RS232, RS485, U Disk, Ethernet.
- ◆ Support up to 32 axes linear interpolation, arbitrary circular interpolation, helical interpolation, and spline interpolation.
- ◆ Support electronic cam, electronic gear, position latch, synchronous follow, virtual axis, and other functions.
- ◆ Support hardware comparison output (HW\_PSWITCH2), hardware timer, precision output when in motion.
- ◆ Support pulse closed loop, pitch compensation and other functions.
- ◆ Support multi-file and multi-task programming in ZBasic.
- ◆ A variety of program encryption methods to protect the intellectual property rights of customers.
- ◆ Support power failure detection and power failure storage. (It can detect and save when power-off)

### 1.3. System Frame

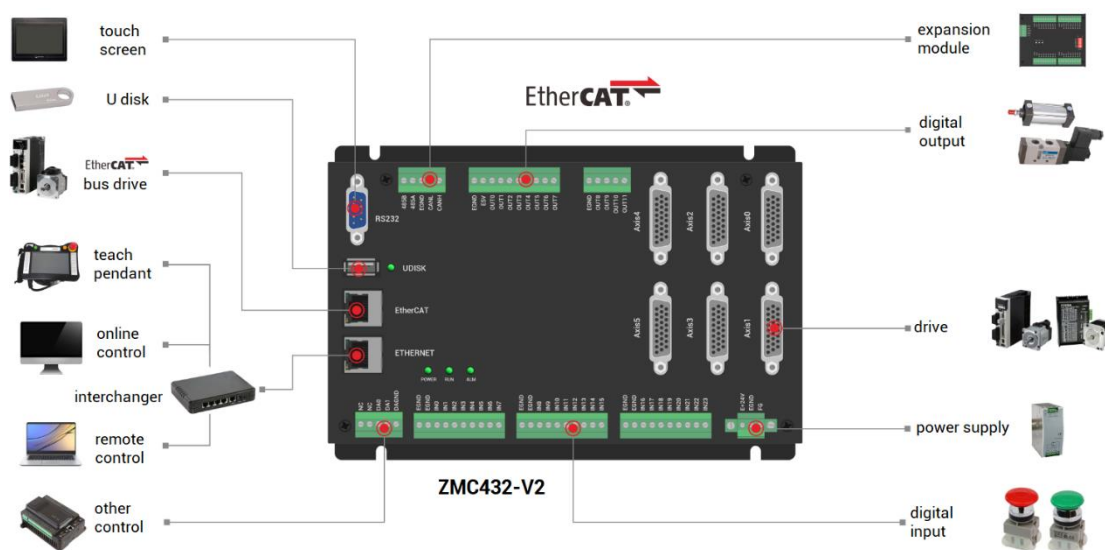



## 1.4. Hardware Installment

The ZMC432-V2 motion controller is installed horizontally with screws, and each controller should be fastened with 4 screws.

→ Unit: mm

→ Mounting Hole Diameter 4.5mm

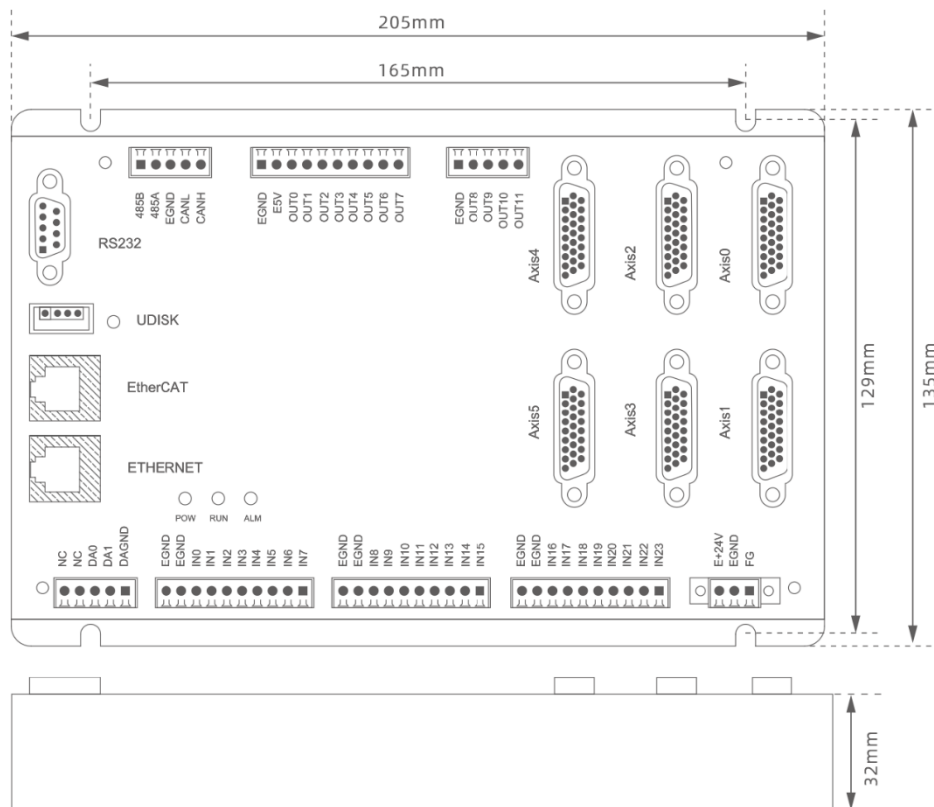

### Installation attention

- Non-professionals are strictly prohibited to operate. Specifically, professionals who had been trained related electrical equipment, or who master electrical knowledge.
- Please be sure to read the product instruction manual and safety precautions carefully before installation.
- Before installation, please ensure that the product is powered off.
- Do not disassemble the module, otherwise the machine may be damaged.
- In order to facilitate ventilation and controller replacement, 2-3cm should be left between the upper and lower parts of the controller and the installation environment and surrounding components.

- |  |   |
|--|---|
|  | <ul style="list-style-type: none"><li>● Considering the convenient operation and maintenance of the controller, please <b>do not</b> install the controller in the following places:<ul style="list-style-type: none"><li>a) places where the surrounding ambient temperature exceeds the range of <math>-10^{\circ}\text{C}</math>-<math>55^{\circ}\text{C}</math></li><li>b) places where the ambient humidity exceeds the range of 10%-95% (non-condensing)</li><li>c) places with corrosive gases and flammable gases</li><li>d) places with many conductive powders such as dust and iron powder, oil mist, salt, and organic solvents</li><li>e) there is direct sunlight</li></ul></li></ul> |
|--|---|

## Chapter II Product Specification

### 2.1. Basic Specification

Item	Description	
Model	ZMC432-V2	ZMC432-16-V2
Basic Axes	32	16
Max Extended Axes	32	32
Type of Basic Axes	EtherCAT, there are 6 local pulse axes.	
Digital IO	There are 24 inputs and 12 outputs, and each pulse axis has 1 input and 1 output.	
Max Extended IO	4096 inputs, 4096 outputs	
PWM	4	
AD/DA	2 general DAs, 0-10V	
Max Extended AD/DA	1000 ADs, 1000 DAs	
Pulse Bit	64	
Encoder Bit	64	
Speed and Acceleration Bit	64	
Highest Pulse Frequency	10MHz	
Motion Buffer of Each Axis	4096	
Array Space	320000	
Program Space	32MByte	
Flash Space	256MByte	
Power Supply Input	24V DC input	
Communication Interfaces	RS232, RS485, Ethernet, U disk, CAN, EtherCAT	
Dimensions	205mm*135mm	

## 2.2. Order Information

Model	Description
ZMC432-V2	32 axes, point to point, linear, circular, electronic cam, continuous trajectory motion, robot structure.
ZMC432-16-V2	16 axes, point to point, linear, circular, electronic cam, continuous trajectory motion, robot structure.
ZMC432-16R-V2	Functions of ZMC432-16-V2 + Delta + 6-joint robot structure.

## 2.3. Interface Definition

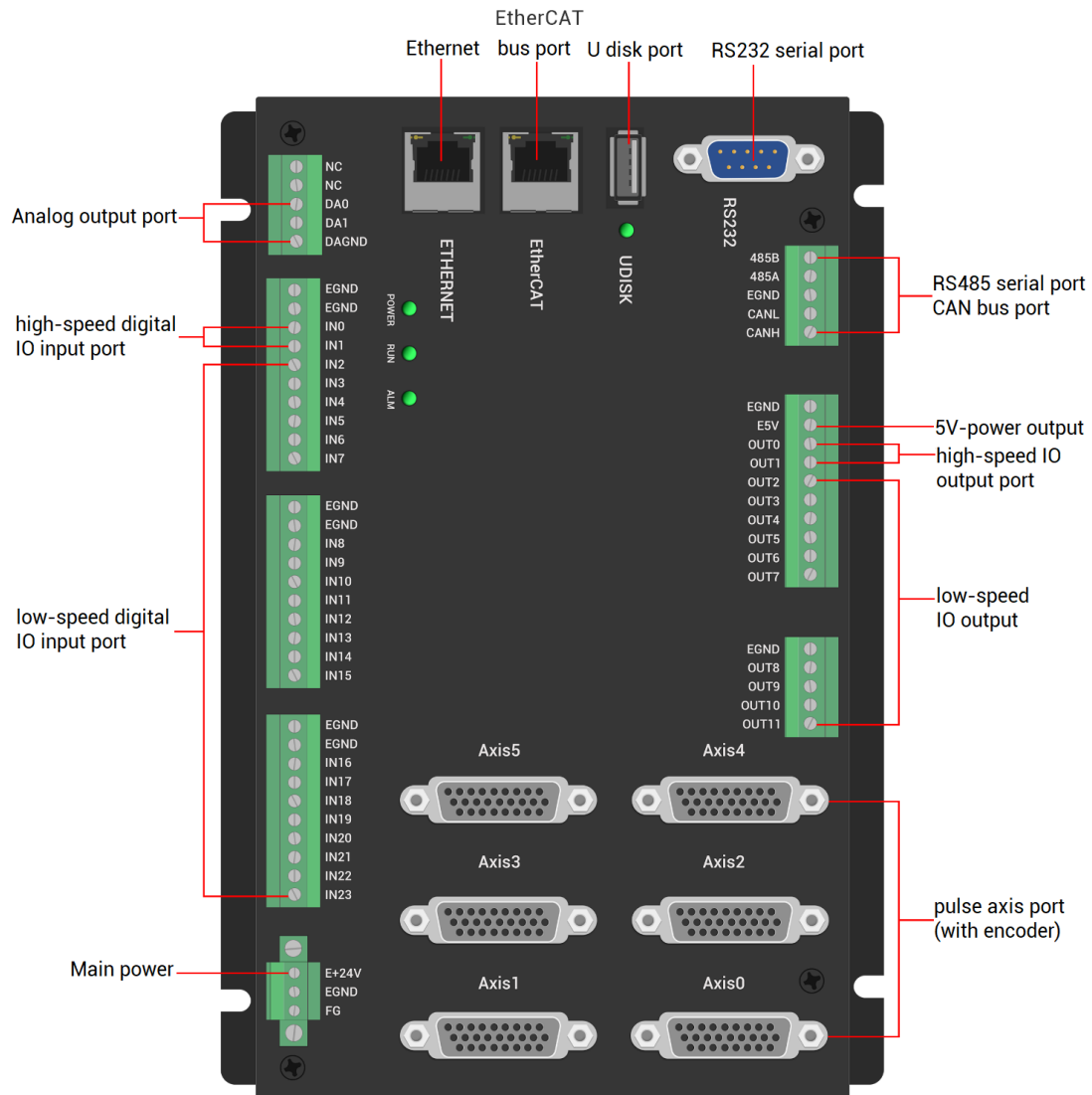

### → Interface Description

Mark	Interface	Number	Description
POW	The led that indicates the current state.	1	Power state: it lights when power is conducted.
RUN		1	Run state: it lights when runs normally
ALM		1	Error state: it lights when runs incorrectly
RS232	RS232 serial port (port0)	1	Use MODBUS_RTU protocol
RS485	RS485 serial port (port1)	1	Use MODBUS_RTU protocol

EtherCAT	EtherCAT bus interface	1	EtherCAT bus interface, connect to EtherCAT bus drive and EtherCAT bus expansion module
ETHERNET	Network port	1	Use MODBUS_TCP protocol, expand the number of network ports through the interchanger, and the number of net port channels can be checked through "?*port" command, default IP address is 192.168.0.11
UDISK	U disk interface	1	Insert U disk equipment
E+24V	Main power supply	1	24V DC power, it supplies the power for controller.
CAN	CAN bus interface	1	Connect to CAN expansion modules and other standard CAN devices.
IN	Digital IO input port	24	NPN type, the power is supplied by internal 24V power supply. There are 2 high-speed inputs, and IN0-1 have the latch function.
OUT	Digital IO output port	12	NPN leakage type, the power is supplied by internal 24V power supply, OUT0-3 have PWM and hardware comparison output functions.
DA	Analog output port	2	12-bit resolution, 0-10V.
AXIS	Pulse axis interface	6	It includes differential pulse output and differential encoder input.

## 2.4. Work Environment

Item		Parameters
Work Temperature		-10℃-55℃
Work relative Humidity		10%-95% non-condensing
Storage Temperature		-40℃ ~ 80℃ (not frozen)
Storage Humidity		Below 90%RH (no frost)
vibration	Frequency	5-150Hz
	Displacement	3.5mm(directly install)(<9Hz)

	Acceleration	1g(directly install>(>9Hz)
	Direction	3 axial direction
Shock (collide)		15g, 11ms, half sinusoid, 3 axial direction
Degree of Protection		IP20

# Chapter III Wiring, Communication Configuration

## 3.1. Power Input

The power supply input adopts a 3Pin (there are all 3 terminals, E+24V, EGND and FG) screw-type pluggable wiring terminal, and the interval (means the gap distance between two ports, namely, between E+24V and EGND) should be 3.81mm. This 3Pin terminal is the power supply of the controller.

### → Terminal Definition:

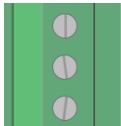
Terminal	Name	Type	Function
	E+24V	Input	Positive (+) terminal of DC power input (connect positive of power to positive of controller)
	EGND	Input	Negative (-) terminal of power input
	FG	Earthing (Grounding)	Protection

### 3.1.1. Power Specification

#### → Specification

Item	Description
Voltage	DC24V(-5%~5%)
The current to open	≤0.5A
The current to work	≤0.4A
Anti-reverse connection	YES



Overcurrent Protection	YES
------------------------	-----

## 3.2. RS485, CAN Communication Interface

The communication interface adopts a 5Pin screw-type pluggable wiring terminal and the gap spacing between 2 terminals should be 3.81mm. For both RS485 communication and CAN communication, they can be used by connecting the corresponding interface.

### → Terminal Definition:

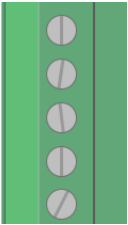
Terminal	Name	Function
485B 485A EGND CANL CANH 	485B	485-
	485A	485+
	EGND	External power supply ground
	CANL	CAN differential data -
	CANH	CAN differential data +

### 3.2.1. RS485, CAN Communication Specification & Wiring

The RS485 serial port supports the MODBUS\_RTU protocol and custom communication, mainly including 485A, 485B and public end.

The CAN interface of the controller adopts the standard CAN communication protocol, which mainly includes three ports, CANL, CANH and the public end. And it can connect to CAN expansion modules and other standard CAN devices.

### → Specification

Item	RS485	CAN
Maximum Communication Rate (bps)	115200	1M
Terminal Resistor	No	120Ω
Topological Structure	Daisy Chain Topology	
The number of nodes can be extended	Up to 127	Up to 16

Communication Distance	The longer communication distance is, the lower communication rate is, and maximum of 30m is recommended.
------------------------	---

### → Wiring Reference

Connect 485A and 485B of RS485 to 485A and 485B of the controller correspondingly, and connect the public ends of RS485 communication parties together.

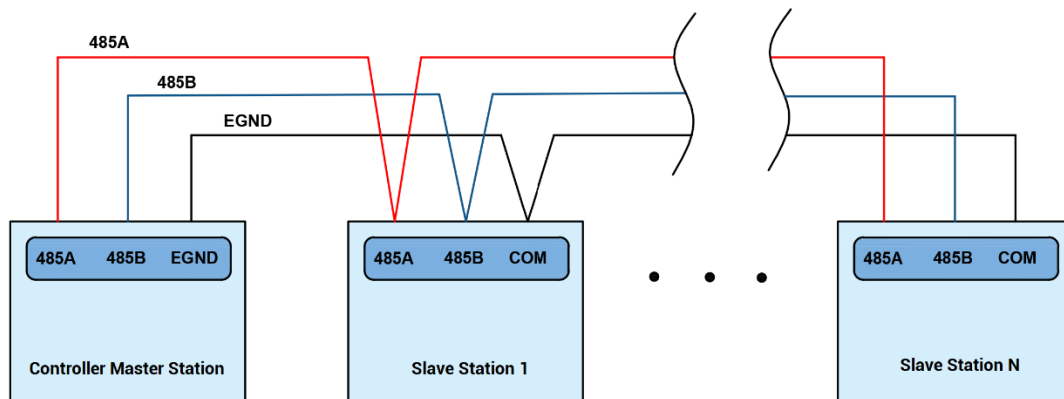

Connect the CANL and CANH of the standard CAN module to the CANL and CANH of the other side correspondingly. And public ends of the CAN bus communication both parties are connected to together. And in CAN bus left and right sides, connect a 120Ω resistor respectively (please see below graphic).

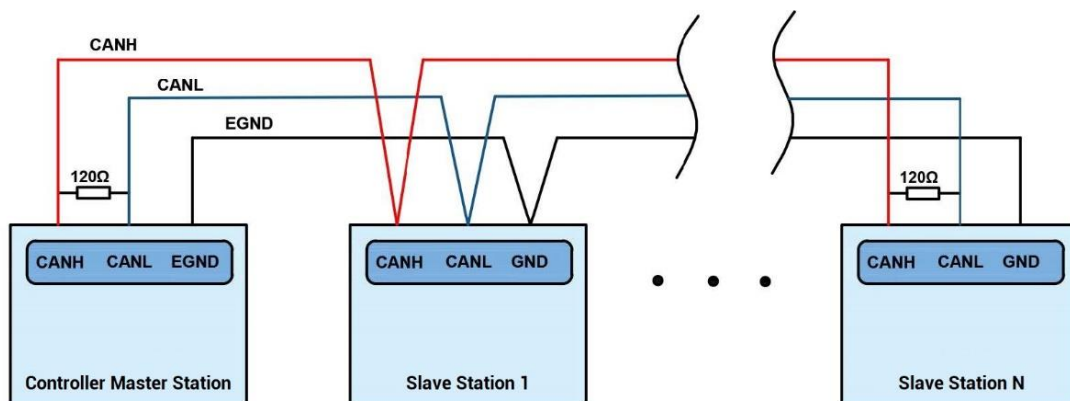

### → Wiring Notes:

- As above, the daisy chain topology is used for wiring (the star topology structure cannot be used). When the use environment is ideal and there are no many nodes,

the branch structure also can be used.

- Please connect a 120Ω terminal resistor in parallel to each end of the CAN bus for matching the circuit impedance and ensuring communication stability.
- Please be sure to connect the public ends of each node on the CAN bus to prevent the CAN chip from burning out.
- Please use STP (Shielded Twisted Pair), especially in bad environments, and make sure the shielding layer is fully grounded.
- When on-site wiring, pay attention to make the distance between strong current and weak current, it is recommended for the distance to be more than 20cm.
- It should be noted that the equipment grounding (chassis) on the entire line must be good, and the grounding of the chassis should be connected to the standard factory ground pile.

### → Cable Requirements:

Shielded Twisted Pair, and the shielded cable is grounded.

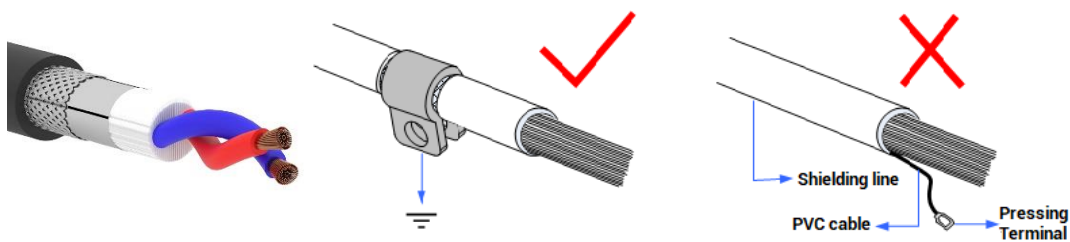

## 3.2.2. Basic Usage Method

- (1) Please follow the above wiring instructions to wiring correctly.
- (2) After powered on, please use any one interface among the three interfaces (ETHERNET, RS232, RS485) to connect to ZDevelop;

- (3) Please use the "ADDRESS" and "SETCOM" commands to set and view the protocol station number and configured parameters, see "ZBasic Programming Manual" for details.
- (4) Please use the "CANIO\_ADDRESS" command to set the master's "address" and "speed" according to the needs, and use the "CANIO\_ENABLE" command to enable or disable the internal CAN master function, or through "ZDevelop/Controller/State the Controller/Communication Info" to view the CAN status intuitively, and refer to the "ZBasic Programming Manual" for details.

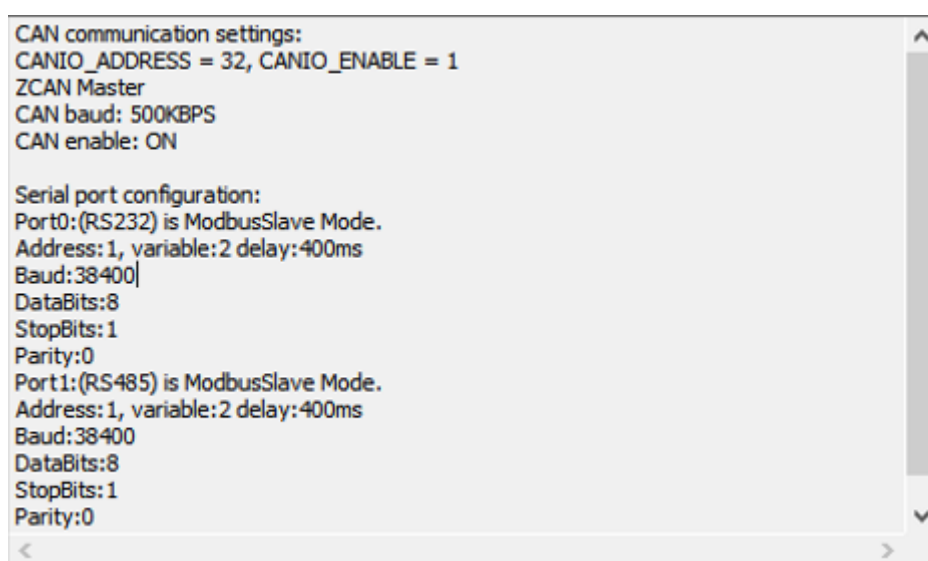

```
CAN communication settings:
CANIO_ADDRESS = 32, CANIO_ENABLE = 1
ZCAN Master
CAN baud: 500KBPS
CAN enable: ON

Serial port configuration:
Port0:(RS232) is ModbusSlave Mode.
Address: 1, variable:2 delay:400ms
Baud:38400
DataBits:8
StopBits: 1
Parity:0
Port1:(RS485) is ModbusSlave Mode.
Address: 1, variable:2 delay:400ms
Baud:38400
DataBits:8
StopBits: 1
Parity:0
```

- (5) According to their respectively instructions, correctly set the relevant parameters of the third-party equipment to match the parameters of each node.
- (6) Correctly set the "address" and "speed" of the slave station expansion module according to the manual of the slave station.
- (7) After all the settings are completed, restart the power supply of all stations to establish communication.
- (8) Note that the "speed" settings of each node on the CAN bus must be consistent, and the "address" settings cannot cause conflicts, otherwise the "ALM" alarm light will be on, and the communication establishment will fail or the communication will be disordered.

### 3.3. RS232 Serial Port

RS232 is in one standard DB9 male socket and supports MODBUS\_RTU protocol and custom communication.

#### → Interface Definition:

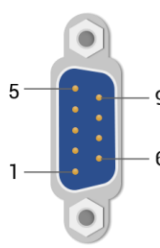
Terminal	PIN	Name	Type	Function
	1, 4, 6, 7, 8	NC	Spare	Reserved
	2	RXD	Input	RS232 signal, receive data
	3	TXD	Output	RS232 signal, send data
	5	EGND	Output	Negative pole output of 5V power, and output for the public end
	9	E5V	Output	Positive pole output of 5V power, maximum is 300mA

#### 3.3.1. RS232 Communication Interface Specification & Wiring

#### → Specification:

Item	RS232
Maximum Communication Rate (bps)	115200
Terminal Resistor	No
Topology Structure	Connect correspondingly (1 to 1)
The number of nodes can be extended	1
Communication Distance	The Longer communication distance is, the lower communication rate is, maximum 5m is recommended.

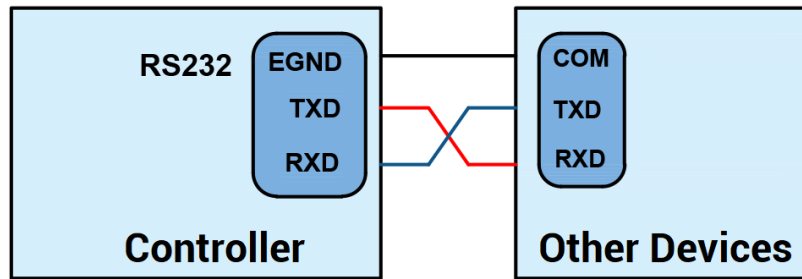
**→ Wiring Reference:****→ Wiring Notes:**

- The wiring of RS232 is as above, it needs to cross-wiring for sending and receiving signals, and it is recommended to use a double-female head cross line when connecting to a computer.
- Please be sure to connect the public ends of each communication node to prevent the communication chip from burning out.
- Please use STP, especially in bad environments, and make sure the shielding layer is fully grounded.

**→ Cable Requirements:**

Shielded Twisted Pair, and the shielded cable is grounded.

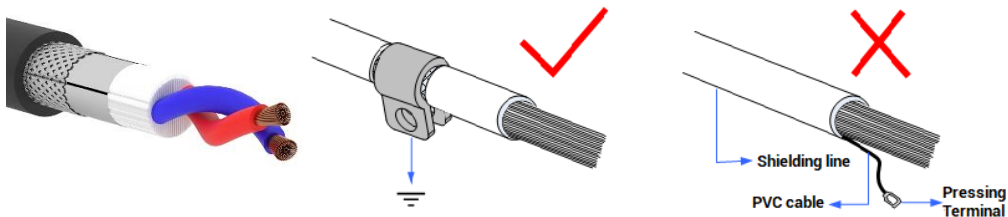

### 3.3.2. Basic Usage Method

- (1) Please follow the above wiring instructions to wiring correctly.

- (2) After powered on, please use any one interface among the three interfaces ETHERNET, RS232 (there are default parameters, which can be connected directly) and RS485 (there are default parameters, which can be connected directly, but for hardware, adapter head is needed) to connect to ZDevelop.
- (3) Please use the "ADDRESS" and "SETCOM" commands to set and view the protocol station number and configured parameters, see "ZBasic Programming Manual" for details.
- (4) According to their respectively instructions, correctly set the relevant parameters of the third-party equipment to match the parameters of each node.
- (5) When all is configured, it can start to do communicating.
- (6) Communication data of RS232 / RS485 can be directly viewed through "ZDevelop / Controller / State the Controller / CommunicationInfo".

```
CAN communication settings:
CANIO_ADDRESS = 32, CANIO_ENABLE = 1
ZCAN Master
CAN baud: 500KBPS
CAN enable: ON

Serial port configuration:
Port0:(RS232) is ModbusSlave Mode.
Address: 1, variable:2 delay:400ms
Baud:38400
DataBits:8
StopBits: 1
Parity:0
Port1:(RS485) is ModbusSlave Mode.
Address: 1, variable:2 delay:400ms
Baud:38400
DataBits:8
StopBits: 1
Parity:0
< >
```

### 3.4. IN Digital Input & High-Speed Latch Port & Single-Ended Encoder

The digital input adopts 3 groups of 10Pin (there are 3 groups of 10 terminals) screw-

type pluggable terminals, and the gap distance between terminals should be 3.81 mm. In addition, the high-speed latch function and single-ended functions are integrated in digital input signals.

→ Terminal Definition

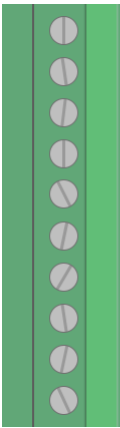
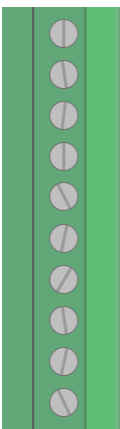
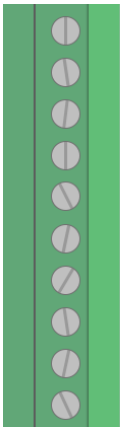
Terminal	Name	Type	Function 1	Function 2	Function 3
	EGND	/	IO Public End	/	/
	EGND	/		/	/
	IN0	NPN type, high-speed input	Input 0	High Speed Latch	EA (AXIS 6)
	IN1		Input 1		EB (AXIS 6)
	IN2	NPN type, low-speed input	Input 2	/	
	IN3		Input 3	/	
	IN4		Input 4	/	
	IN5		Input 5	/	
	IN6		Input 6	/	
	IN7		Input 7	/	
	EGND		/	IO Public End	/
	EGND	/	/		
	IN8	NPN type, low-speed input	Input 8	/	
	IN9		Input 9	/	
	IN10		Input 10	/	
	IN11		Input 11	/	
	IN12		Input 12	/	
	IN13		Input 13	/	
	IN14		Input 14	/	
	IN15		Input 15	/	
	EGND	/	IO Public End	/	
	EGND	/		/	
	IN16	NPN type, low-speed input	Input 16	/	
	IN17		Input 17	/	
	IN18		Input 18	/	
	IN19		Input 19	/	
	IN20		Input 20	/	
	IN21		Input 21	/	
	IN22		Input 22	/	
	IN23		Input 23	/	

Note:

When the controller's firmware version is above 20170515, IN0-1 support single-ended encoder



function, and it must use **AXIS\_ADDRESS** command to map, then configure **ATYPE**, while mapping, the physical axis No. axis 6 should be used. If **AXIS\_ADDRESS** command is not used for mapping, it only sets **ATYPE**, then it can't identify physical axis 6. At this time, if operates axis 6, it may recognize axis 0, then operate axis 0, the error will be caused. When **ATYPE** = 0, IN 0 -1 are ordinary inputs.

### 3.4.1. Digital Input Specification & Wiring

#### → Specification

Item	High-Speed Input (IN0-1)	Low-Speed Input (IN2-23)
Input mode	NPN leakage type, the input is triggered when there is low-electric level	
Frequency	< 100kHz	< 5kHz
Impedance	3.3KΩ	4.7KΩ
Voltage level	DC24V	DC24V
The voltage to open	<15V	<14.5V
The voltage to close	>15.1V	>14.7V
Minimal current	-2.3mA (negative)	-1.8mA (negative)
Max current	-7.5mA (negative)	-6mA (negative)
Isolation mode	optoelectronic isolation	

Note: the above parameters are standard values when the voltage of controller power supply (E+24V port) is 24V.

#### → Wiring Reference

##### General Wiring:

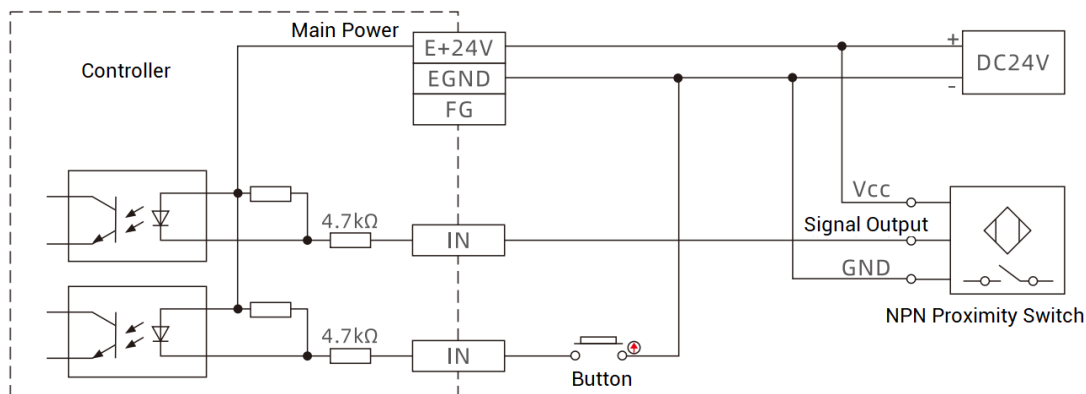

### Single-Ended Encoder Wiring:

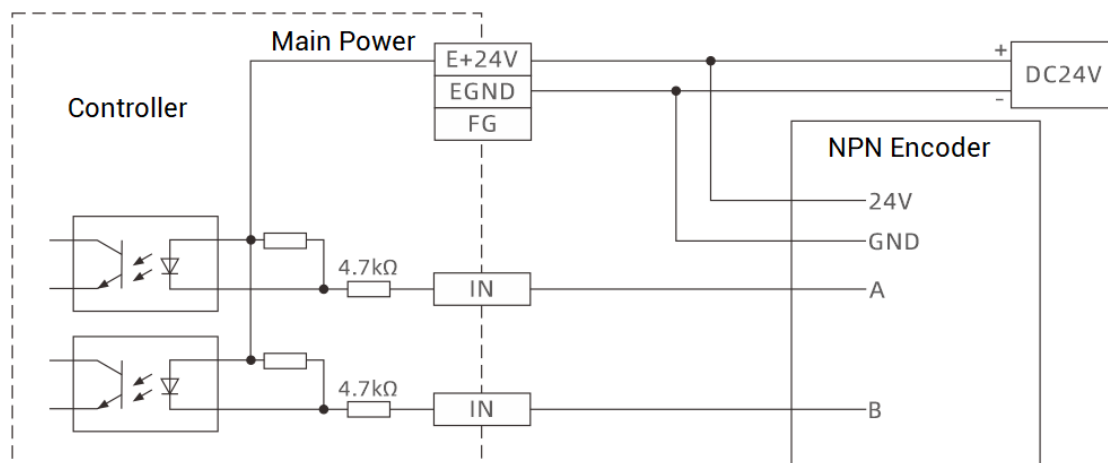

#### → Wiring Note:

- The wiring principle of high-speed digital input IN (0-1) and low-speed digital input IN (2-23) is shown in the figure above. The external signal source can be an optocoupler, a key switch or a sensor, etc., all can be connected as long as the requirements on output of electric level can be achieved.
- For the public end, please connect the "EGND" port on the power supply to the "COM" terminal of the external input device. If the signal area power supply of the external device and the power supply of the controller are in the same power supply system, this connection also can be omitted.

### 3.4.2. Basic Usage Method

- (1) Please follow the above wiring instructions to wiring correctly.
- (2) After powered on, please select any one interface among the three interfaces ETHERNET, RS232 and RS485 to connect to ZDevelop.
- (3) State values of relative input ports can be read directly through "IN" command, also, it can be read through "ZDevelop/View/In". Please refer to "ZBasic" for details.

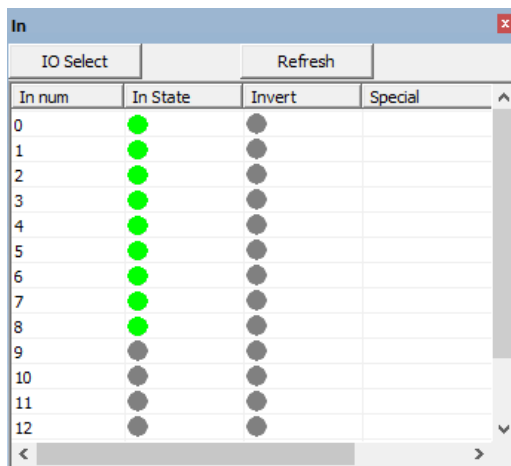

(4) Latch function can be set and triggered through "REGIST" instruction, in software, use REG\_INPUTS to configure. Please refer to "ZBasic" for details.

(5) How to map axis while using IN0-1 single-ended encoder function

AXIS\_ADDRESS (axis No. to be mapped) = (-1<<16) + the local pulse axis No. to be modified, now physical axis 6 is used.

BASE (axis No. to be mapped)

ATYPE = 0

BASE (the local pulse axis No. to be modified, now physical axis 6 is used)

ATYPE = 0

BASE (axis No. to be mapped)

ATYPE = the axis is with encoder

### 3.5. OUT (Digital Output, PWM Terminal, Hardware Comparison Output, Single-Ended Pulse)

The digital output adopts 2 sets of screw-type pluggable terminals with a spacing of 3.81mm, and the PWM and hardware comparison output, and single-ended pulse-axis functions are integrated in digital output signals.

#### → Terminal Definition

Terminal	Name	Type	Function 1	2	Function 3	4
	EGND	/	IO public end / 5V power	/	/	

			ground			
	E5V	/	5V power output, max is 300mA	/	/	
	OUT0	NPN	Output 0	PWM 0	Hardware Comparison Output	PUL6 (AXIS 6)
	OUT1	Leakage type, high-speed out	Output 1	PWM 1		DIR6 (AXIS 6)
	OUT2	NPN Leakage type, low-speed out	Output 2	PWM 2		PUL7 (AXIS 7)
	OUT3		Output 3	PWM 3	DIR7 (AXIS 7)	
	OUT4		Output 4	/	/	
	OUT5		Output 5	/	/	
	OUT6	Output 6	/	/		
	OUT7	Output 7	/	/		
		EGND	/	IO public end	/	/
OUT8		NPN	Output 8	/	/	
OUT9		Leakage	Output 9	/	/	
OUT10		type, low-speed out	Output 10	/	/	
OUT11		speed out	Output 11	/	/	
<p><b>Notes:</b></p> <ul style="list-style-type: none"> <li>✧ The E5V power output port is used for PWM or common anode wiring of single-ended axis. It is not recommended for other purposes due to lower power.</li> <li>✧ OUT0-3 have the functions of PWM and hardware comparison output, among which OUT2 and 3 are low-speed outputs.</li> <li>✧ OUT0-3 support single-ended pulse-axis (axis 6 &amp; axis 7), and <b>it must use <code>AXIS_ADDRESS</code> command to map, then configure <code>ATYPE</code></b>. When <code>ATYPE</code> = 0, they are general outputs.</li> </ul>						

### 3.5.1. Digital Output Specification & Wiring

#### → Specification

Item	High Speed Output (OUT0-1)	Low Speed Output (OUT2-11)
Output mode	NPN leakage type, it is 0V when outputs	
Frequency	< 400kHz	< 8kHz
Voltage level	DC24V	DC24V

Max output current	+300mA	+300mA
Max leakage current when off	25μA	25μA
Respond time to conduct	1μs (resistive load typical value)	12μs
Respond time to close	3μs	80μs
Overcurrent protection	Support	Support
Isolation method	optoelectronic isolation	

**Note:**

- ✧ The times in the form are typical based on the resistive load, and may change when the load circuit changes.
- ✧ Due to the leak-type output, the shutdown of the output will be obviously affected by the external load circuit, and the output frequency should not be set too high in the application.

→ **Wiring Reference**

**General Wiring:**

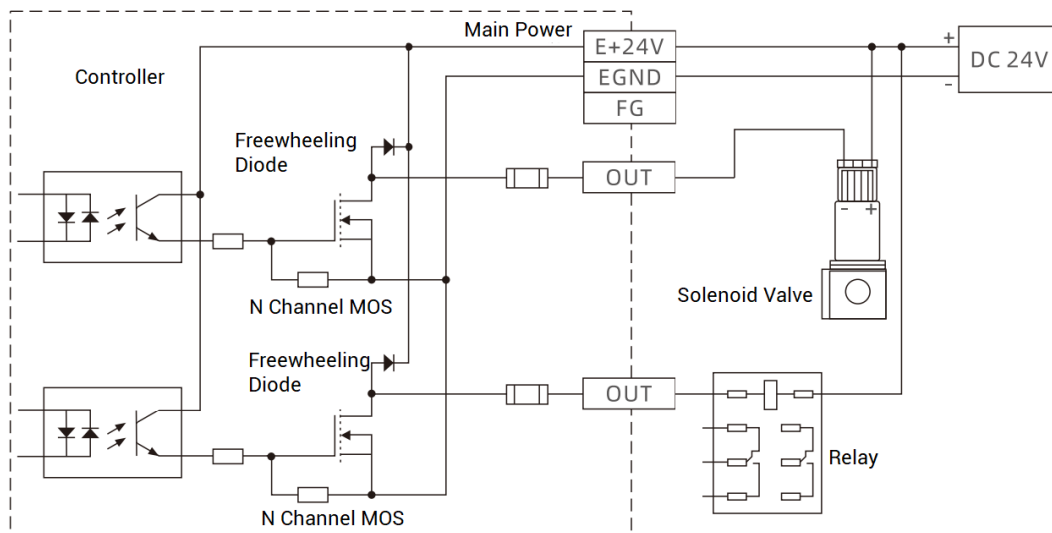

**Single-Ended Pulse Wiring (24V):**

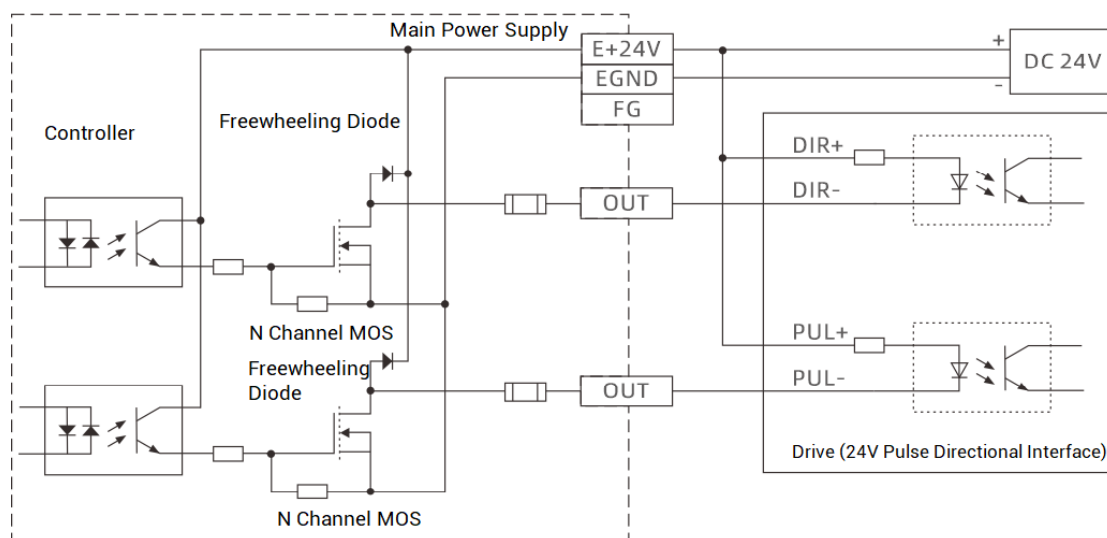

**Single-Ended Pulse Wiring (5V):**

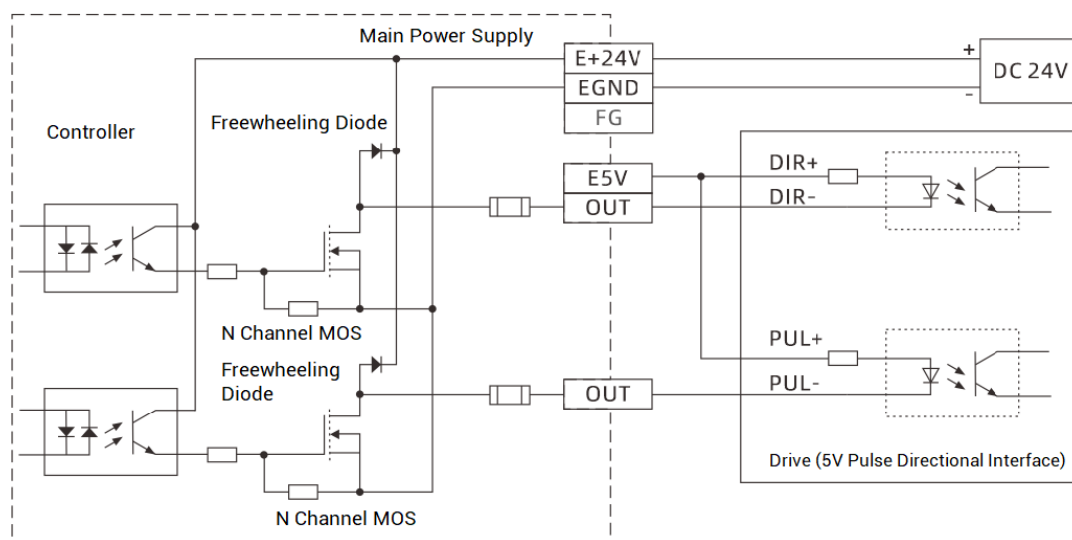

**→ Wiring Note:**

- The wiring principle of high-speed digital output OUT (0-1) and low-speed digital output OUT (2-11) is shown in the figure above. The external signal receiving end can be an optocoupler or a relay or solenoid valve, all can be connected as long as the input current does not exceed 300mA.
- For the connection of the public end, please connect the "EGND" port on the power

supply to the negative pole of the DC power supply of the external input device. If the DC power supply of the external device and the controller power supply are in the same power supply system, this connection can also be omitted.

- The E5V port is a 5V power output port, which can be used when some loads need to provide an external 5V power input, the maximum current is 300mA.

### 3.5.2. Basic Usage Method

- (1) Please follow the above wiring instructions to wiring correctly.
- (2) After powered on, please use any one interface among the three interfaces ETHERNET, RS232 and RS485 to connect to ZDevelop.
- (3) Open or close output port directly through "OP" command, also, it can be opened or closed through "ZDevelop/View/Op". Please refer to "ZBasic" for details.

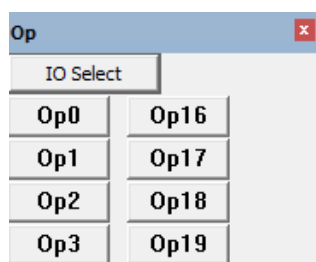

- (4) The PWM function, set the frequency and duty cycle through "PWM\_FREQ" and "PWM\_DUTY". Please refer to ZBasic for details.
- (5) Hardware comparison output can be set and opened through "HW\_PSWITCH2". Please refer to ZBasic for details.
- (6) How to map axis when using OUT0-1 single-ended pulse function:

AXIS\_ADDRESS (axis No. to be mapped) = (-1<<16) + the local pulse axis No. to be modified, now physical axis 6 and axis 7 are used.

BASE (axis No. to be mapped)

ATYPE = 0

BASE (the local pulse axis No. to be modified, now physical axis 6 and axis 7 are used)

ATYPE = 0

BASE (axis No. to be mapped)

ATYPE = the axis is with pulse output

## 3.6. DA Analog Output

The analog port adopts a set of 5Pin screw-type pluggable terminals with a spacing of 3.81mm.

### → Terminal Definition

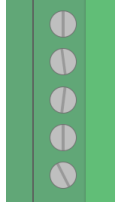
Terminal	Name	Type	Function
	NC	Spare	Reserved
	NC		Reserved
	DA0	Output	Analog output terminal: AOUT(0)
	DA1		Analog output terminal: AOUT(1)
	DAGND	Public End	Analog public end

### 3.6.1. Analog Output Specification & Wiring

#### → Specification

Item	DA (0-1)
Resolution	12-bit
Data range	0-4095
Signal range	0-10V output
Data refresh ratio	1KHz
Voltage output load	>1KΩ

#### → Wiring Reference

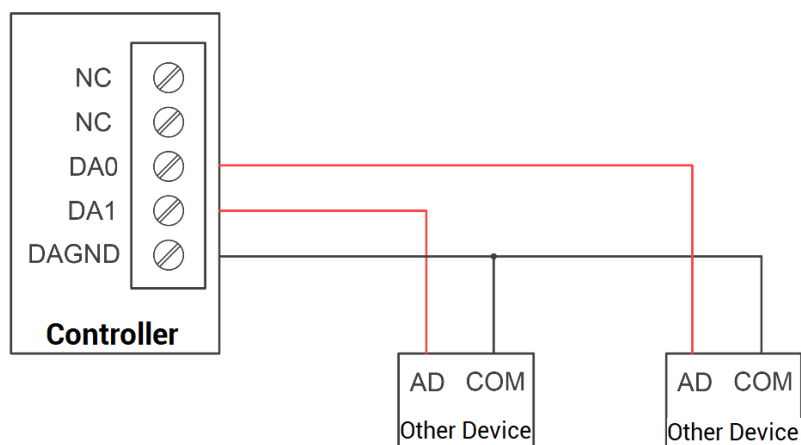



### → Wiring Note:

- The analog input/output wiring method is as shown in the figure above, and the external load signal range must match with this signal range.
- Please use STP, especially in bad environments, and make sure the shielding layer is fully grounded.

### → Cable Requirements:

Shielded Twisted Pair, and the shielded cable is grounded.

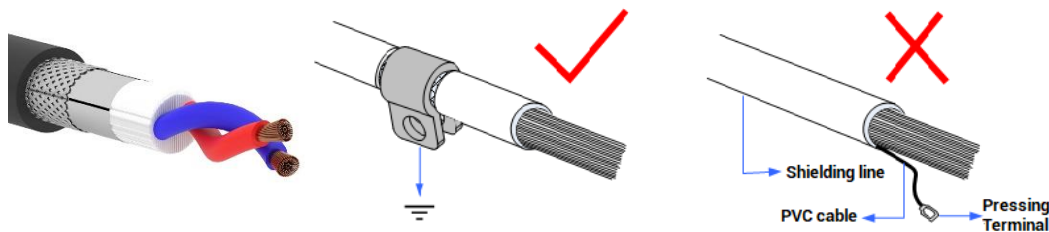

## 3.6.2. Basic Usage Method

- (1) Please follow the above wiring instructions to wiring correctly.
- (2) After powered on, please use any one interface among the three interfaces ETHERNET, RS232 and RS485 to connect to ZDevelop.
- (3) Analog input voltage can be read through "AIN" command and corresponding analog voltage can be output through "AOUT" command, also, data of each channel can be checked through "ZDevelop/View/AD/DA". Please refer to "ZBasic" for details.

DA:						
Channel number	Size	Scale value	V or mA value	Maximum scale	V or mA Range	
0	0%	0	0.000	4095	0~10V	
1	0%	0	0.000	4095	0~10V	

### 3.7. U Disk

The ZMC432-V2 motion controller provides a USB communication interface, which can insert the U disk device. It is used for ZAR program upgrading, controller data importing and exporting, file 3 executing, etc. Its schematic diagram is shown in the figure below:

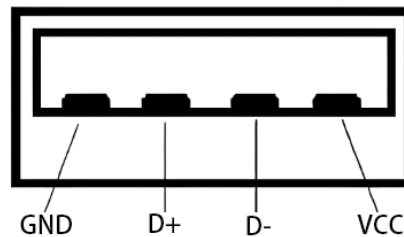

#### → Specification

Item	USB2.0
Highest Communication Ratio	12Mbps
Max Output Current of 5V	500mA
Whether Isolates	No

### 3.8. ETHERNET

ZMC432-V2 motion controller has a 100M network port, and it supports MODBUS\_TCP protocol and custom communication, the default IP address is 192.168.0.11. While connecting to controller, both sides' IP are in same network segment, but with different IP addresses (for example: personal PC default network segment is 192.168.0.xxx (non-11 are OK)). Following shows PIN definitions:

The diagram shows an 8-pin Ethernet connector with lines connecting each pin to the corresponding row in the table below.

PIN	Signal	Description
1	TX+	Send signal (+)
2	TX-	Send signal (-)
3	RX+	Receive signal (+)
4	NC	Reserved
5	NC	Reserved
6	RX-	Receive signal (-)
7	NC	Reserved
8	NC	Reserved

The Ethernet port of the controller can be connected to a computer, HMI, etc. through an Ethernet cable, and point to point connection method is used. The schematic diagram is as follows:

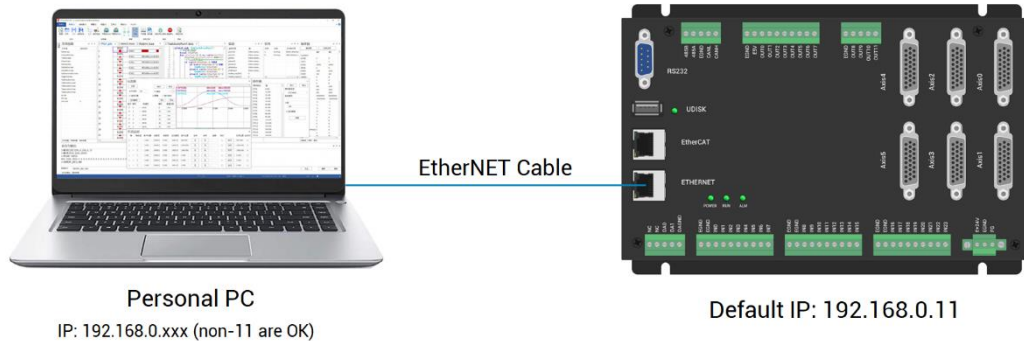

The controller can also be connected to the interchanger through an Ethernet cable, and then use interchanger to connect to other devices, then multi-point connection can be achieved. The schematic diagram is as follows:

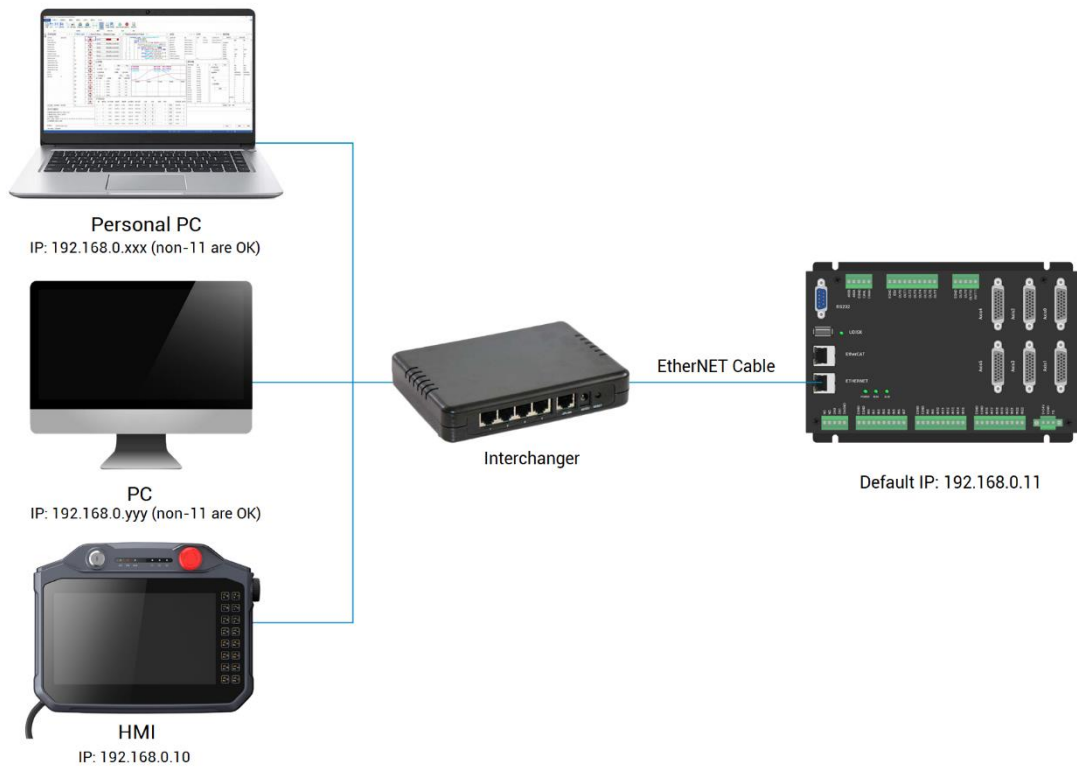

### 3.9. EtherCAT Bus Interface

ZMC432-V2 motion controller has a 100M EtherCAT communication interface, and it supports EtherCAT protocol. In addition, EtherCAT driver or EtherCAT expansion module can be connected. The pin definition is as follows:

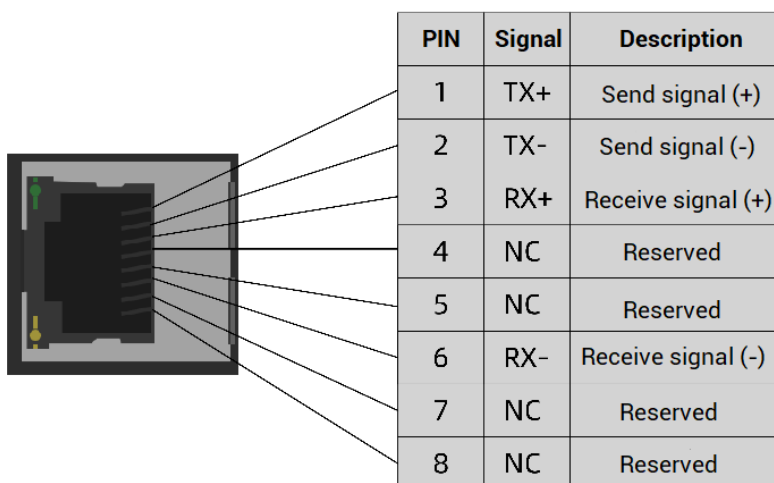

#### → Specification

Item	Specification
Communication protocol	EtherCAT protocol
Valid service	CoE(PDO, SDO), FoE
Synchronization method	IO adopts input and output synchronization / DC-distributed clock
Physical level	100BASE-TX
Duplex mode	Full duplex
Topology	linear topology
Transfer media	Cable
Transfer distance	It is less than 100M between 2 nodes
Process data	Maximum 1486 bytes of one single frame
Synchronization shaking of two slave stations	<1us
Refresh	For 1000 digital input and output, about 30us

#### → Communication Cable Requirements

Both ETHERNET communication interface and EtherCAT communication interface

adopt standard Ethernet RJ45 interface.

The network cable adopts Category 5e STP, and the crystal head has a metal shell to reduce interference and to prevent information from being eavesdropped. As shown below:

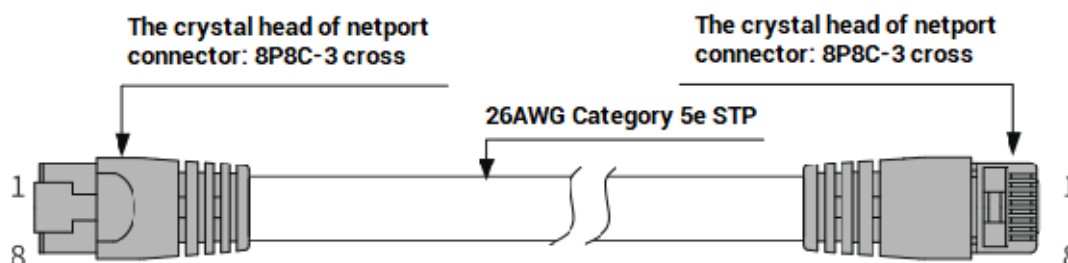

Item	Specification
Cable type	Flexible crossover cable, Category 5e
traverse	twisted pair
Line pairs	4
Isolation	cross skeleton
Connector	Crystal head with iron shell
Cable material	PVC
Cable length	Less than 100m

#### Use RJ45 network cable connection method:

- When installing, hold the crystal head that is with the cable and insert it into the RJ45 interface until it makes a "click" sound (kada).
- In order to ensure the stability of communication, please fix the cables with cable ties.
- When disassembling, press the tail mechanism of the crystal head, and pull out the connector and the module in a horizontal direction.

Please use tube-type pre-insulated terminals and cables with appropriate wire diameters to connect the user terminals.

### 3.10. AXIS Differential Pulse Axis Interface

This product provides 6 local differential pulse axis interfaces, each interface is a standard DB26 female socket. Each terminal provides 0V and +5V output, which can

provide 5V power for the encoder.

Before the axis is used, use ATYPE instruction to configure the axis type.

## → Interface Definition

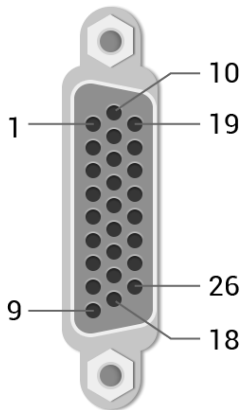
Interface	Pin	Signal	Description
	1	EGND	Negative pole of IO 24V power
	2	IN24- 29/ALM	General input (recommended as driver alarm)
	3	OUT12- 17/ENABLE	General output (recommended as driver enable)
	4	EA-	Encoder differential input signal A-
	5	EB-	Encoder differential input signal B-
	6	EZ-	Encoder differential input signal Z- / <b>SSI_DAT-</b> / <b>BISS_DAT -</b>
	7	+5V	Positive pole of 5V power of pulse/encoder signal
	8	Reserved	Reserved
	9	DIR+	Servo or step directional output differential signal +
	10	GND	Negative pole of 5V power of pulse/encoder signal
	11	PUL-	Servo or step pulse output differential signal - / <b>SSI_CLK-</b> / <b>BISS_CLK -</b>
	12	Reserved	Reserved
	13	GND	Negative pole of 5V power of pulse/encoder signal
	14	OVCC	Positive pole of IO 24V power
	15	Reserved	Reserved
	16	Reserved	Reserved
	17	EA+	Encoder differential input signal A+
	18	EB+	Encoder differential input signal B+
	19	EZ+	Encoder differential input signal Z+

			/ SSI_DAT+ / BISS_DAT +
	20	GND	Negative pole of 5V power of pulse/encoder signal
	21	GND	
	22	DIR-	Servo or step direction output differential signal -
	23	PUL+	Servo or step pulse output differential signal + / SSI_CLK+ / BISS_CLK +
	24	GND	Negative pole of 5V power of pulse/encoder signal
	25	Reserved	Reserved
	26	Reserved	Reserved

**Note:**

- ✧ ALM and ENABLE are recommended to be used as axis IO, because the drive capacity is small.
- ✧ OVCC, +5V are only used for communication between the controller and the servo driver, please do not use it as power supply for other places.
- ✧ SSI / BISS absolute values use PUL signal to do as CLK output, and use EZ signal to do as DAT input, therefore, they can't use as pulse-axis at the same time. But when EZ is not needed for AB encoder, synchronous use can be valid.
- ✧ If the controller's firmware is with Ssi, which means it supports SSI/BISS absolute value encoder.
- ✧ Then, check the controller state, it can be seen ZMC432-V2 Axis 4 and Axis 5 support SSI/BISS absolute value encoder.

Pulse-axis PIN and IO corresponding relation:

Pulse-Axis No.	Corresponding IN (PIN2)	Corresponding OUT (PIN3)
AXIS 0	24	12
AXIS 1	25	13
AXIS 2	26	14
AXIS 3	27	15
AXIS 4	28	16
AXIS 5	29	17

### 3.10.1. AXIS Interface Signal Specification & Wiring

#### → Specification:

Signal	Item	Description
PUL/DIR	Signal type	Differential output signal
	Voltage range	0-5V
	Maximum frequency	10MHz
EA/EB/EZ	Signal type	Differential input signal
	Voltage range	0-5V
	Maximum frequency	5MHz
IN24-29	Input method	NPN type, it is triggered when low electric level is input.
	Frequency	< 5kHz
	Impedance	6.8K $\Omega$
	Voltage level	DC24V
	The voltage to open	<10.5V
	The voltage to close	>10.7V
	Minimal current	-1.8mA (negative)
	Maximum current	-4mA (negative)
	Isolation	optoelectronic isolation
OUT12-17	Output method	NPN leak type, it is 0V when outputs
	Frequency	< 8kHz
	Voltage level	DC24V
	Maximum current	+50mA
	Overcurrent protection	No
	Isolation	optoelectronic isolation
+5V, GND	Maximum output current for 5V	50mA
OVCC, EGND	Maximum output current for 24V	50mA

#### → Wiring Reference:

Reference example of wiring with Panasonic A5/A6 servo driver:



**DB26 Controller Pulse-Axis**

**Panasonic A5 A6 Servo Drive**

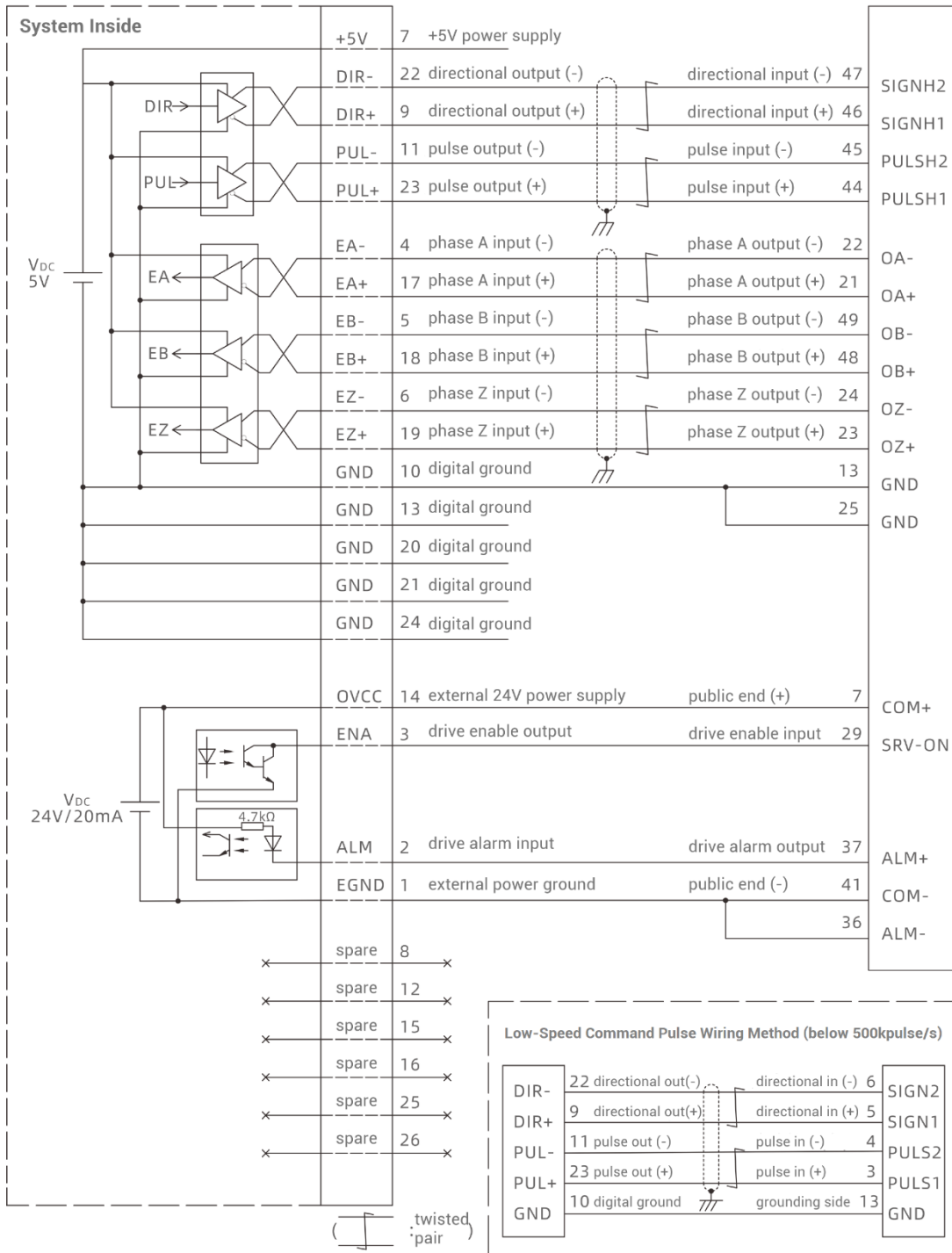

**Wiring Reference of PUL/DIR common anode:**

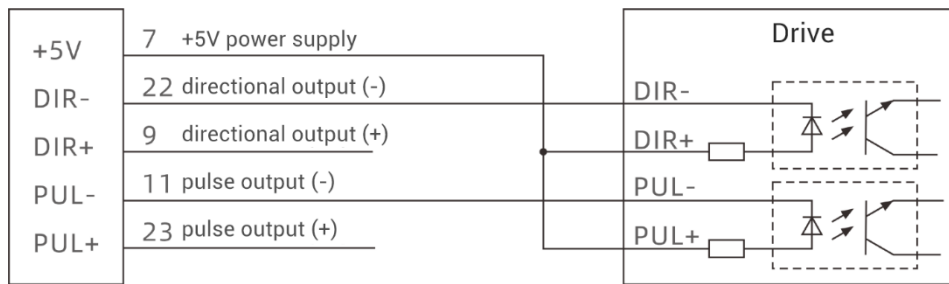

**Wiring Reference of EA/EB/EZ common anode:**

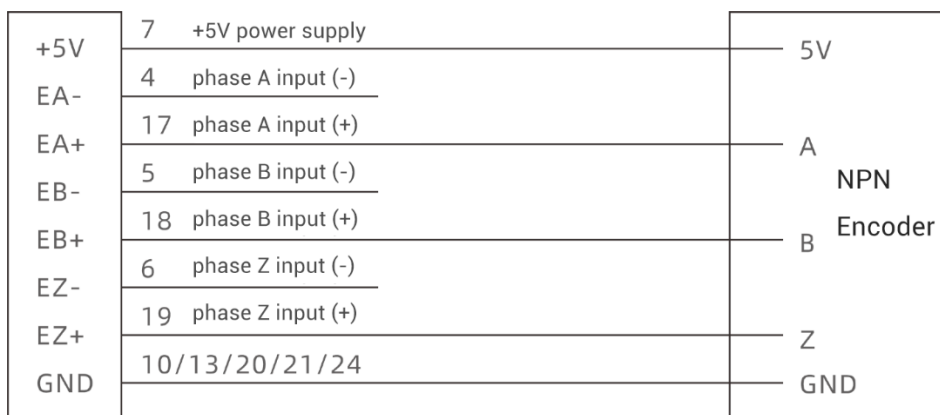

**Wiring of absolute encoder:**

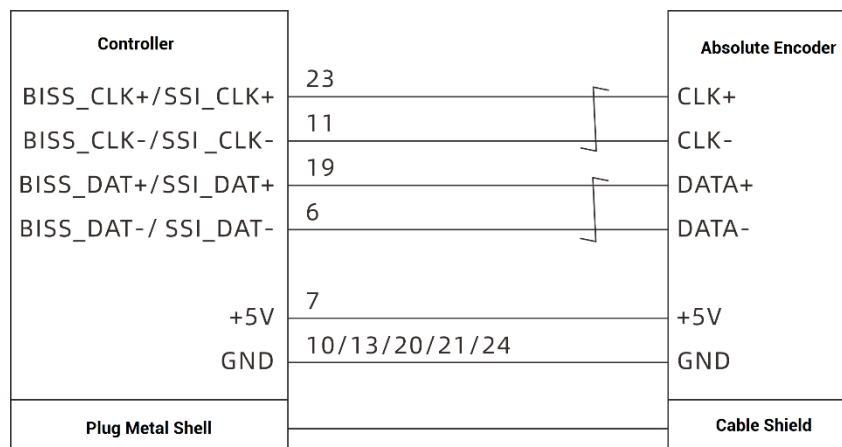

**→ Wiring Note:**

- ✧ The wiring principle of the differential pulse axis interface is shown in the figure above, and the wiring methods of different types of drivers are different, please

connect carefully.

- ✧ Please use STP, especially in bad environments, and make sure the shielding layer is fully grounded.

### 3.10.2. Basic Usage Method

- (1) Please follow the above wiring instructions to wiring correctly.
- (2) After powered on, please use any one interface among the three interfaces ETHERNET, RS232 (default parameter, it can be connected directly) and RS485 (default parameters, it can be connected directly, but for hardware, adapter head is needed) to connect to ZDevelop.
- (3) Set axis parameters, such as, ATYPE, UNITS, SPEED, ACCEL, FWD\_IN, REV\_IN, etc.
- (4) There are many parameters related to pulse axis, they can be set and checked through relative instructions, please see "axis parameter and axis status" of "ZBasic", or see "ZDevelop/View/Axis parameter".

	Axis0	Axis1	Axis2	Axis3
COMMENT				
ATYPE	0	0	0	0
UNITS	1	1	1	1
ACCEL	10000	10000	10000	10000
DECEL	0	0	0	0
SPEED	1000	1000	1000	1000
CREEP	100	100	100	100
LSPEED	0	0	0	0
MERGE	0	0	0	0

- (5) Control corresponding motion through "View – Manual".

Axis	ATYPE	UNITS	ACCEL	DECEL	SPEED	DPOS	Left/Move	Right/Move	Distance	Absolute	MPOS	IDLE	AXISSTATUS		
0	0	1.000	10000.0	0.000	1000.00	0.000	Left	Right		<input type="checkbox"/>	Move	0.000	-1	0h	Stop
1	0	1.000	10000.0	0.000	1000.00	0.000	Left	Right		<input type="checkbox"/>	Move	0.000	-1	0h	Stop
2	0	1.000	10000.0	0.000	1000.00	0.000	Left	Right		<input type="checkbox"/>	Move	0.000	-1	0h	Stop
3	0	1.000	10000.0	0.000	1000.00	0.000	Left	Right		<input type="checkbox"/>	Move	0.000	-1	0h	Stop
4	0	1.000	10000.0	0.000	1000.00	0.000	Left	Right		<input type="checkbox"/>	Move	0.000	-1	0h	Stop
5	0	1.000	10000.0	0.000	1000.00	0.000	Left	Right		<input type="checkbox"/>	Move	0.000	-1	0h	Stop

**Refer to BASIC Routine:**

BASE(0,1)	'select axis 0 and axis 1
ATYPE = 1,1	'set axis 0 and axis 1 as pulse axes
UNITS = 1000,1000	'set pulse amount as 1000 pulses
SPEED = 10,10	'set axis speed as 10*1000 pulse/s
ACCEL = 1000,1000	'set axis acceleration as 1000*1000 pulse/s/s
FWD_IN = -1,-1	'prohibit using axis positive hardware position limit
REV_IN = -1,-1	'prohibit using axis negative hardware position limit
MOVE(10) AXIS(0)	'axis 0 moves distance of 10*1000 pulses in positive
MOVE(-20) AXIS(0)	'axis 0 moves distance of 20*1000 pulses in negative

## Chapter IV Expansion Module

The controller can expand digital IO, analog IO, pulse axis and other resources through CAN bus or EtherCAT bus. That is, it can use together with ZIO series CAN expansion modules, EIO series EtherCAT expansion modules, or ZMIO310 series vertical expansion modules. For details, please refer to corresponding user manual.

### 4.1. CAN Bus Expansion

ZIO series expansion modules or ZMIO310-CAN coupler with sub modules can be used.

#### 4.1.1. CAN Bus Expansion Wiring

The ZIO expansion module is powered by the dual power supply. Except the main power supply, an additional IO power supply is required to supply independent power for IO. Both the main power supply and the IO power supply use 24V DC power supply. For ZAIO, it only needs to connect to the main power supply.

To prevent interference, separate the IO power supply from the main power supply.

Please select the expansion module according to the requirements, and select IO mapping or axis mapping according to the resources of the expansion module. Attention the No. must be different while mapping.

Wiring reference of connection between ZIO expansion module and control card and standard wiring of CAN bus are shown as below:

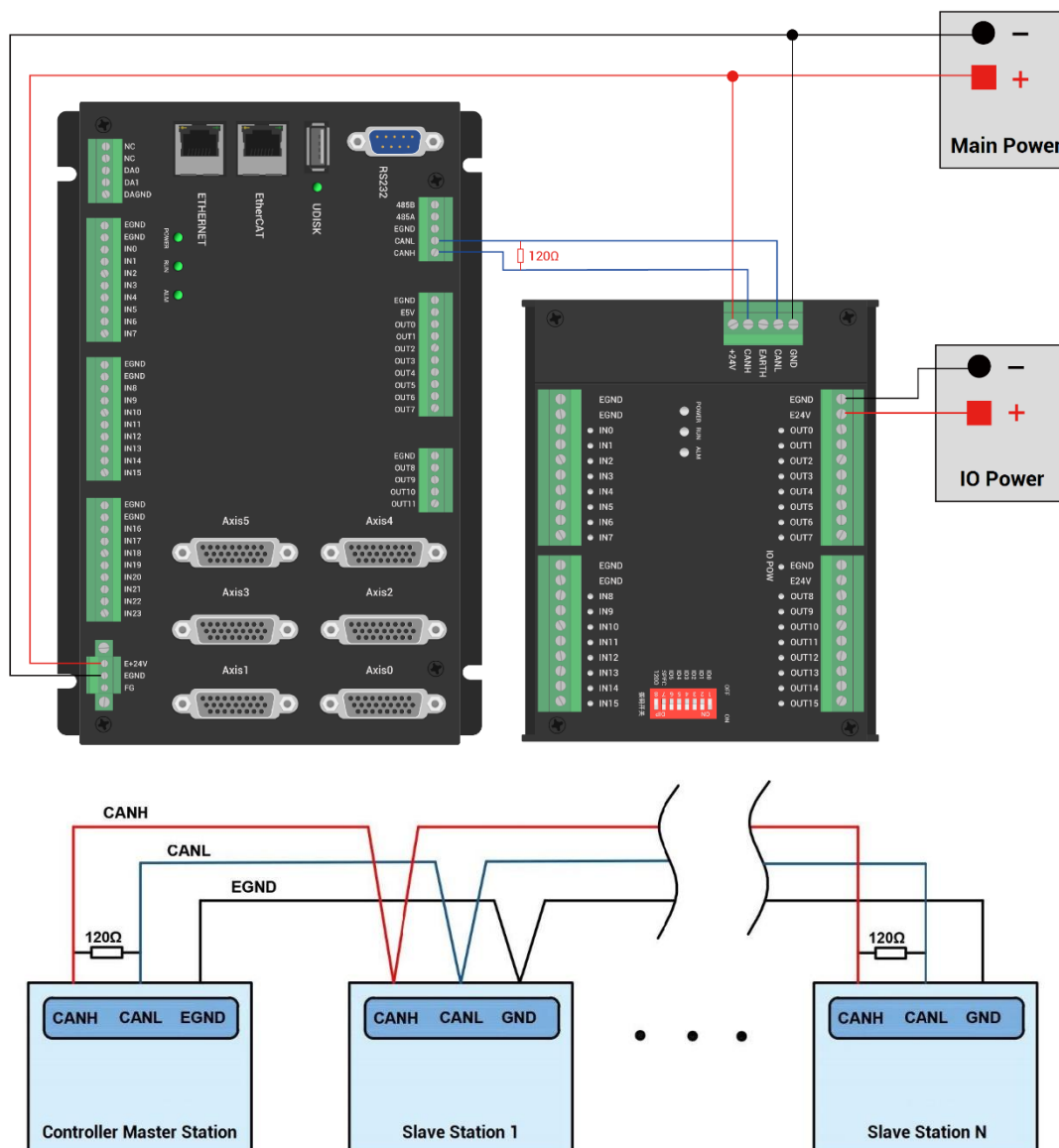

→ **Wiring Note:**

- ✧ ZMC432-V2 controller uses the single power, and ZIO expansion module uses dual-power. When using, main power supply of expansion module and main power supply of controller can share one power. When they use different power supplies, controller power EGND needs to connect to expansion module power GND, otherwise CAN may be burnt out.
- ✧ When connecting multiple ZIO expansion modules on the CAN bus, a 120-ohm resistor needs to be connected in parallel between the CANL and CANH terminals, for the ZIO expansion module that is with 8-digit dialing codes, the terminal resistor can be realized by dialing the code (DIP).

## 4.1.2. CAN Bus Expansion Resource Mapping

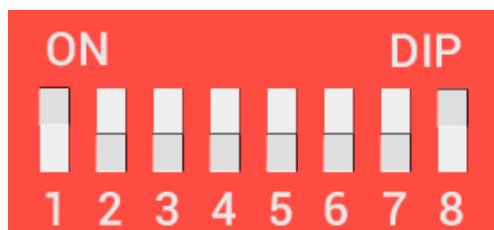

The ZCAN expansion module generally has an 8-code DIP switch, dial ON to take effect, and the meaning of the DIP is as follows:

1-4: they are used for ZCAN expansion module IO address mapping, the corresponding value is 0-15.

5-6: CAN communication speed, corresponding value is 0-3, four different speeds are optional.

7: reserved.

8: 120 ohm resistor, dial ON means a 120 ohm resistor is connected between CANL and CANH.

The IO numbers of the entire control system cannot be repeated, and existed numbers must be avoided when mapping resources. And the DIP switch must be dialed before power-on , if re-dial after power-on, it is invalid. It needs to be powered on again to take effect.

Dial 1-4 to select the CAN address, and the controller sets the IO number range of the corresponding expansion module according to the CAN DIP address. When each is dialed as OFF, the corresponding value is 0, when it is ON , it corresponds to a value of 1, and the address combination value = dial 4  $\times$  8 + dial code 3  $\times$  4 + dial code 2  $\times$  2+ dial code 1.

Dial code 5-6 to select CAN bus communication speed, speed combination value=dial code 6  $\times$  2 + dial code 5 $\times$ 1, the combined value range is 0-3.

The corresponding speeds are as follows:

DIP 5-6 combination value	CANIO_ADDRESS high 8-bit value	CAN communication speed
0	0 (corresponds to decimal 128)	500KBPS (default value)
1	1 (corresponds to decimal 256)	250KBPS
2	2 (corresponding to decimal 512)	125KBPS
3	3 (corresponding to decimal 768)	1MBPS

The controller side sets the CAN communication speed through the CANIO\_ADDRESS

command. There are also four speed parameters that can be selected. The communication speed must be consistent with the communication speed of the expansion module that corresponds to the combination value, then they can communicate with each other.

The factory default communication speed is 500 KBPS on both sides, there is no need to set this, unless you need to change the speed.

The CANIO\_ADDRESS command is a system parameter, and it can set the master-slave end of CAN communication. The default value of the controller is 32, that is, CANIO\_ADDRESS=32 is the master end, and the slave end is set between 0-31.

The CAN communication configuration can be viewed in the "State the Controller" window.

### → IO Mapping:

IO mapping of the CAN expansion module uses code 1-4 of the DIP switch. According to the number of currently included IO points (the largest number in IN and OP must include IO point in the axis interface), use the code 1-4 to set the ID, so as to determine the number range of IO to be expanded.

If the controller itself contains 28 INs and 16 OPs, then the starting address set by the first extended board should exceed the maximum value of 28. According to below rule, the dial code should be set to the combination value 1 (binary combination value 0001, from right to left, dial code 1-4, at this time dial 1 is set to ON, and the others are set to OFF), the IO number on the expansion board = the expansion board number value + the initial IO number value, among them, the IOs that are vacant from 29-31 Numbers are not used. Subsequent extended boards continue to confirm the dial settings according to the IO points in turn.

The initial digital IO mapping number starts from 16 and increases in multiples of 16. The distribution of digital IO numbers corresponding to different dial IDs is as follows:

DIP 1-4 combination value	Starting IO number	Ending IO number
0	16	31
1	32	47
2	48	63
3	64	79
4	80	95
5	96	111
6	112	127



7	128	143
8	144	159
9	160	175
10	176	191
11	192	207
12	208	223
13	224	239
14	240	255
15	256	271

The initial IO mapping number of the analog AD starts from 8 and increases in multiples of 8. The initial IO mapping number of the analog DA starts from 4 and increases in multiples of 4. The allocation of digital IO numbers corresponding to different dial code IDs is as follows:

DIP 1-4 combination value	Starting AD number	End AD number	Starting DA number	End DA number
0	8	15	4	7
1	16	23	8	11
2	24	31	12	15
3	32	39	16	19
4	40	47	20	23
5	48	55	24	27
6	56	63	28	31
7	64	71	32	35
8	72	79	36	39
9	80	87	40	43
10	88	95	44	47
11	96	103	48	51
12	104	111	52	55
13	112	119	56	59
14	120	127	60	63
15	128	135	64	67

### → Axis Mapping:

When the CAN bus expansion mode is used to expand the pulse axis, ZIO16082M can



ALMRM indicator light is on, please check whether the wiring, resistor and dial setting are correct, and whether the CANIO\_ADDRESS command of the controller is set as the master (32), and whether the CAN communication speed is consistent.

## 4.2. EtherCAT Bus Expansion

The EIO expansion modules and ZMIO310-ECAT are expansion modules used by the EtherCAT bus controller. For example, EIO series can expand the resources of digital IO and pulse axis. When the resources of the controller are insufficient, the EtherCAT bus controller can be connected to multiple EIO expansion modules for expansion, you can view the maximum number of IO expansion points and the maximum number of expansion axes of the controller, and in this way, it supports IO remote expansion.

### 4.2.1. EtherCAT Bus Expansion Wiring

After the expansion wiring is completed, each EIO expansion module does not need to develop again. It only needs to manually configure the unique IO address and axis address in the EtherCAT master controller, and it can be accessed after the configuration is completed.

The IO address number is set through the bus command NODE\_IO, and the program on the controller can access the resources on the expansion module only through the IO number. The configuration of the axis address uses the AXIS\_ADDRESS command to map axis number, and when the binding is completed, specify the axis number through the BASE or AXIS command.

When wiring, pay attention that EtherCAT IN is connected to the upper-level module, and EtherCAT OUT is connected to the lower-level module. The IN and OUT ports cannot be mixed.

EIO expansion module wiring reference example:

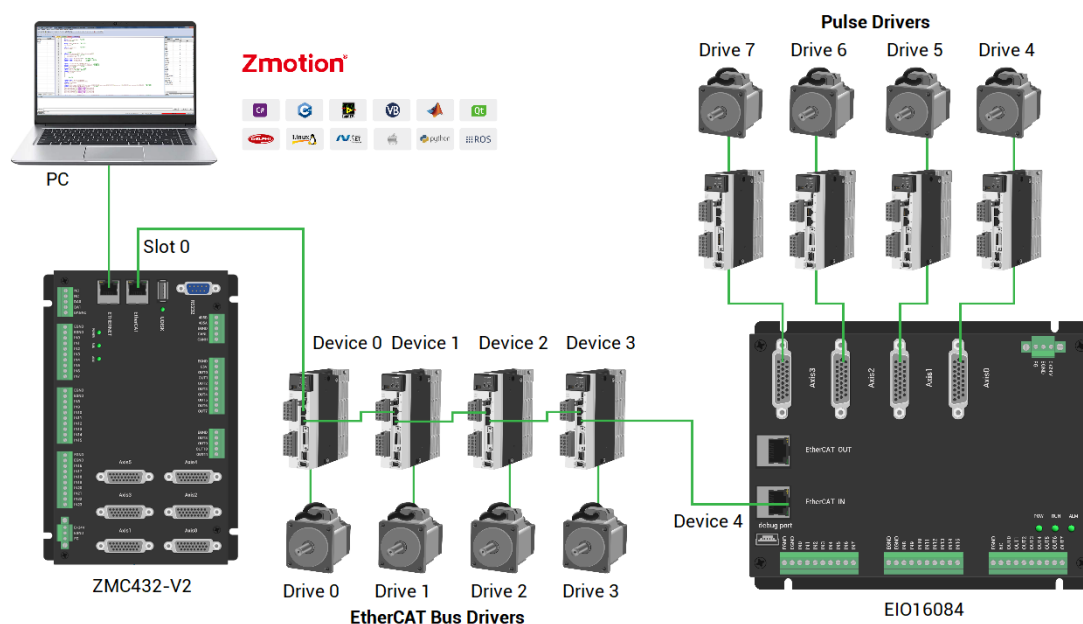

Involved number concepts in above figure are as follows: the bus-related command parameters will use the following numbers:

**Slot number (slot):**

The slot number refers to the number of the bus interface on the controller, and the slot number of the EtherCAT bus is 0.

**Device number (node):**

The device number refers to the number of all devices connected to a slot. It starts from 0 and is automatically numbered according to the connection sequence of the devices on the bus. You can view the total number of devices connected to the bus through the `NODE_COUNT(slot)` command.

**Drive number:**

The controller will automatically identify the drive on the slot, and the number starts from 0, and the number is automatically numbered according to the connection sequence of the drive on the bus.

The drive number is different from the device number. Only the drive device number on the slot is assigned, and other devices are ignored. The drive number will be used when mapping the axis number.

## 4.2.2. EtherCAT Bus Expansion Resource Mapping

→ **IO Mapping:**

The program on the controller can access the resources on the expansion module

only through the IO number. The IO number of the EtherCAT bus expansion module is set through the bus command NODE\_IO, and the input and output are configured at the same time.

When IO mapping, first check the maximum IO number of the controller itself (including the external IO interface and the interface in the pulse axis), and then use the command to set.

If the extended IO coincides with the IO number of the controller itself, the two will work at the same time, so the mapped number of the IO mapping must not be repeated in the entire control system.

#### IO mapping syntax:

NODE\_IO( slot, node ) = iobase

slot: slot number, 0-default

node: device number, starting from 0

iobase : mapping the IO start number, the setting result will only be a multiple of 8

#### Example:

NODE\_IO(0,0)=32            'set the IO start number of slot 0 interface device 0 to 32

If device 0 is EIO16084, after configuration according to the above syntax, the IO numbers corresponding to input IN0-15 are 32-47 in turn, the general input port numbers in the axis interface are 48-55, and the drive alarm inputs of axes AXIS 0-3 are 48-51 respectively. The IO numbers corresponding to the output OUT0-7 are 32-39 in sequence, the general output port numbers in the axis interface are 40-47, and the drive enable outputs of the axes AXIS 0-3 are 40-43 respectively.

0	41bh	1918h	0	4	24(32-55)	16(32-47)	0

#### → **AXIS Mapping:**

Before using the axis of the expansion module, you need to use the AXIS\_ADDRESS command to map the axis number, and the axis mapping also needs to pay attention to the axis number of the entire system cannot be repeated. The mapping syntax of the EIO series extended axis is the same as that of the bus driver.

#### Axis mapping syntax:

AXIS\_ADDRESS( axis number )=(slot number<<16)+driver number+1

**Example:**
$$\text{AXIS\_ADDRESS}(0)=(0 \ll 16)+0+1$$

'the first drive on the EtherCAT bus, drive number 0, bound as axis 0

$$\text{AXIS\_ADDRESS}(1)=(0 \ll 16)+1+1$$

'the second drive on the EtherCAT bus, drive number 1, bound as axis 1

If the first node is EIO16084, and EIO16084 is connected to drive, then driver 0 here is the first pulse driver connected to EIO16084, otherwise it is the EtherCAT driver.

# Chapter V Program & Applications

## 5.1. ZDevelop Software Usage

ZDevelop is a PC-side program development, debugging and diagnostic software for the ZMoiton series motion controllers of Zmotion Technology. Through it, users can easily edit and configure the controller program, quickly develop applications, diagnose system operating parameters in real time, and watch the motion controller. The running program is debugged in real time and supports Chinese and English bilingual environments.

ZBasic, ZPLC and ZHMI can run multi-tasks, and ZBasic can run multi-tasks, and can be mixed with ZPLC and ZHMI.

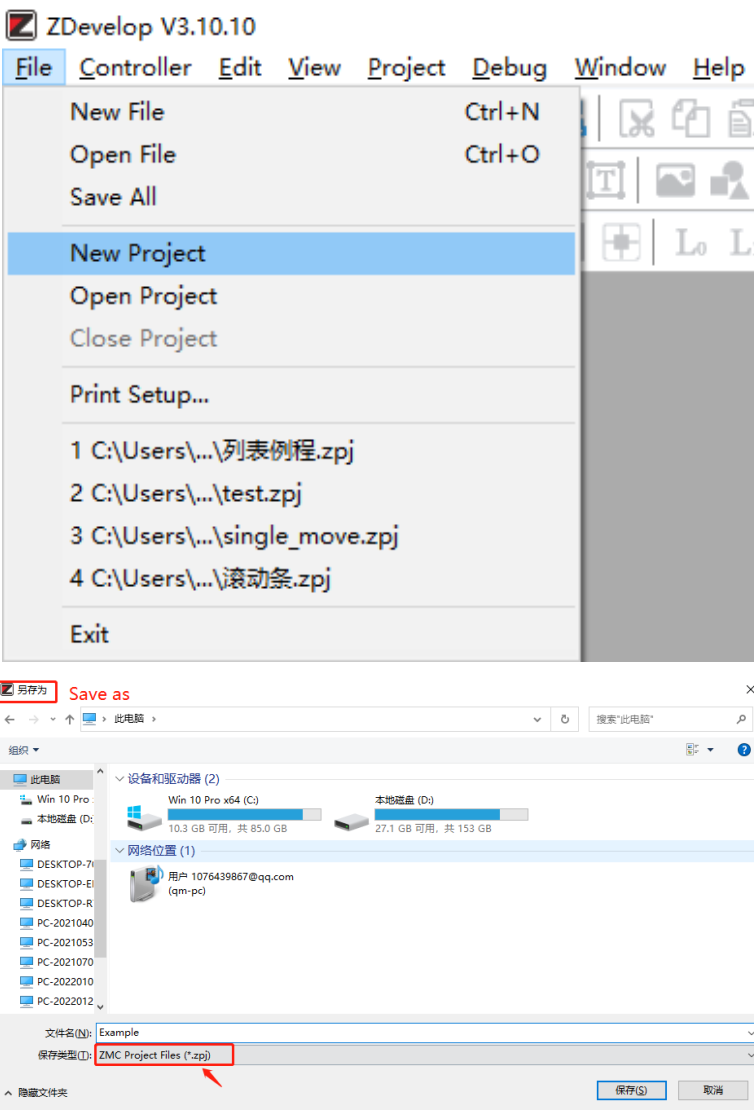
Step	Operations	Display Interface
1	Open ZDevelop, click "File" – "New Project", Save as window will pop up, then enter file name, save the project file with suffix "zpj".	 <p>The screenshot shows the ZDevelop V3.10.10 application window. The 'File' menu is open, and 'New Project' is highlighted. Below the menu, a list of existing project files is visible, including '列表例程.zpj', 'test.zpj', 'single_move.zpj', and '滚动条.zpj'. A 'Save as' dialog box is also open, showing the file name 'Example' and the file type 'ZMC Project Files (*.zpj)' selected. The dialog box also shows the file explorer view with drives C: and D: and a network location.</p>

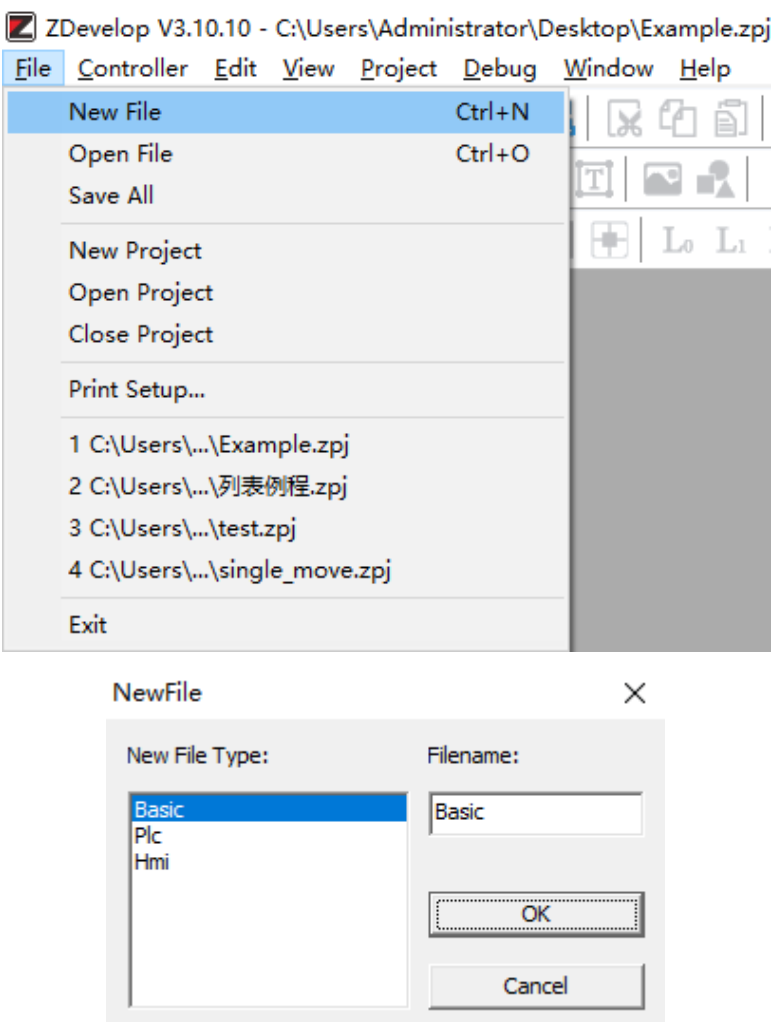
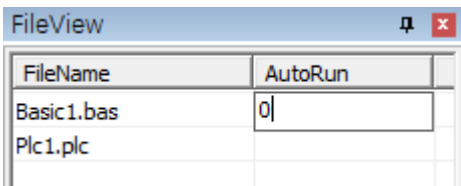
<p>2</p>	<p>Click "File" – "New File", select file type to build, here select Basic, click "OK".</p>	 <p>The screenshot shows the ZDevelop V3.10.10 application window with the 'File' menu open. The 'New File' option is selected, showing a list of recent files. Below the menu, the 'NewFile' dialog box is open, with 'Basic' selected in the 'New File Type' list and 'Basic' entered in the 'Filename' field. The 'OK' button is highlighted.</p>						
<p>3</p>	<p>Double click "AutoRun", enter task number 0.</p>	 <p>The screenshot shows the 'FileView' window containing a table with two columns: 'FileName' and 'AutoRun'. The table lists two files: 'Basic1.bas' and 'Plc1.plc'. The 'AutoRun' column for 'Basic1.bas' contains the value '0'.</p> <table border="1" data-bbox="715 1283 1177 1422"> <thead> <tr> <th>FileName</th> <th>AutoRun</th> </tr> </thead> <tbody> <tr> <td>Basic1.bas</td> <td>0</td> </tr> <tr> <td>Plc1.plc</td> <td></td> </tr> </tbody> </table>	FileName	AutoRun	Basic1.bas	0	Plc1.plc	
FileName	AutoRun							
Basic1.bas	0							
Plc1.plc								

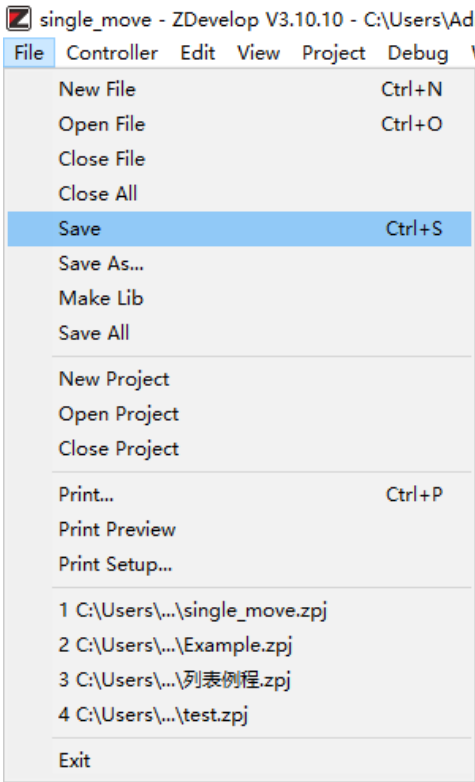
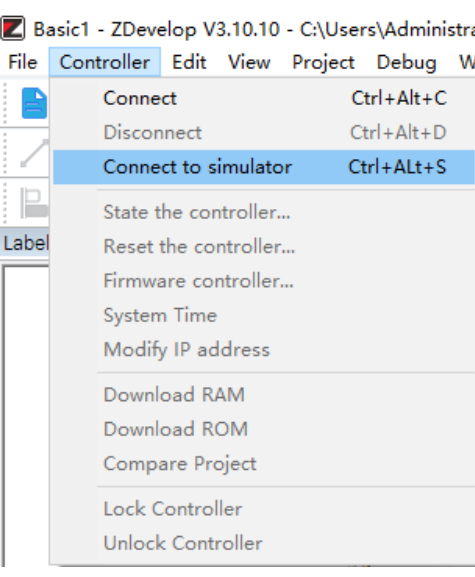
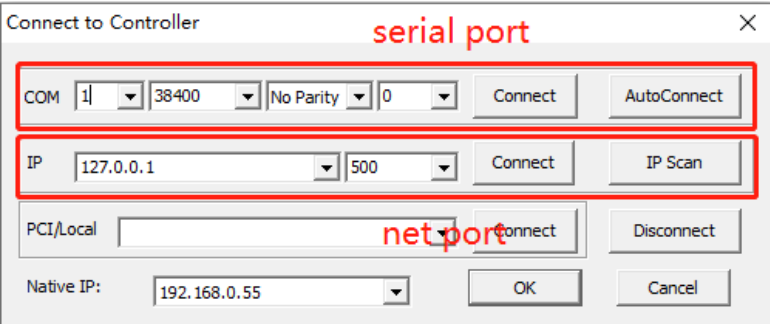

<p>4</p>	<p>Edit the program in program editing window, click "save", new built basic file will be saved under "zpj." project automatically. "Save all" means all files under this project will be saved.</p>	
<p>5</p>	<p>Click "controller – connect", if no controller, select connect to simulator.</p>	
<p>Then, "connect to controller" window will pop up, you can select serial port or net port to connect, select matched serial port</p>	<p></p>	

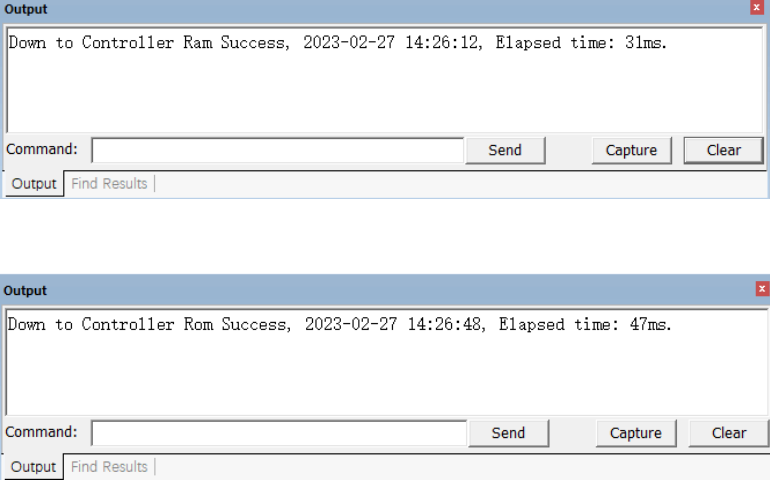
	<p>parameters or net port IP address, then click "connect".</p>	
<p>6</p>	<p>Click "Ram/Rom" – "download RAM / download ROM", if it is successful, there is print indication, at the same time, program is downloaded into controller and runs automatically. RAM: it will not save when power off. ROM: it will save data when power off, and when the program is connected to controller again, running according to task number.</p>	 <p>The image shows two screenshots of the 'Output' window. The top screenshot displays the message: 'Down to Controller Ram Success, 2023-02-27 14:26:12, Elapsed time: 31ms.' The bottom screenshot displays the message: 'Down to Controller Rom Success, 2023-02-27 14:26:48, Elapsed time: 47ms.' Both screenshots include a 'Command:' input field, 'Send', 'Capture', and 'Clear' buttons, and a 'Find Results' button.</p>

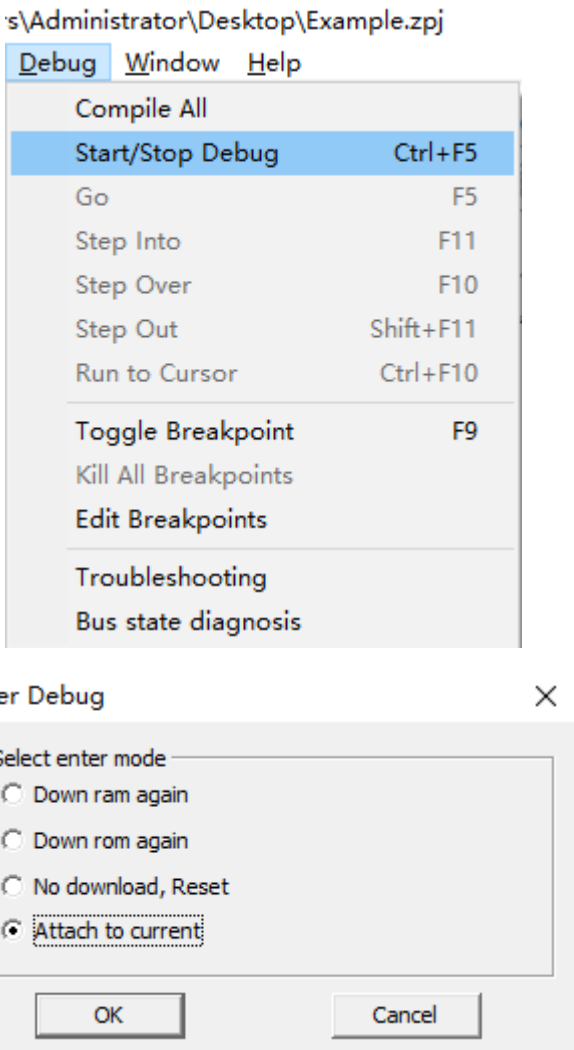
<p>7</p>	<p>Click “Debug” – “Start/Stop Debug” to call “Task” and “Watch” window, because it was downloaded before, here select “Attach the current”.</p>	
----------	--	---

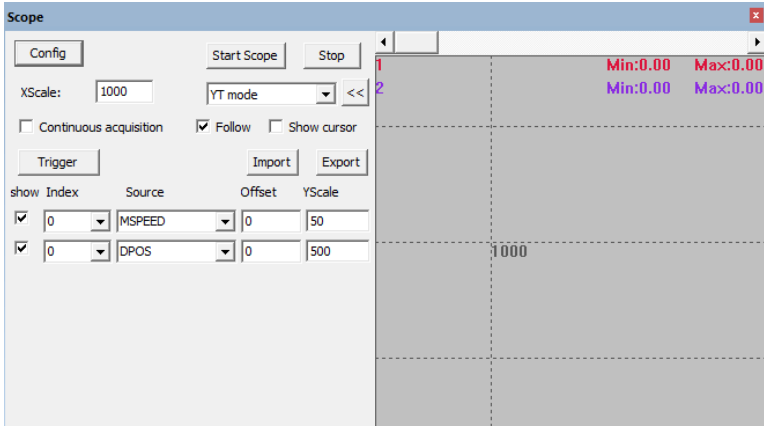
<p>8</p>	<p>Click “View” – “Scope” to open oscilloscope.</p>	
----------	---	--

Note:

- When opening an project, choose to open the zpj file of the project. If only the Bas file is opened, the program cannot be downloaded to the controller.
- When the project is not created, only the Bas file cannot be downloaded to the controller.
- The number 0 in automatic operation represents the task number, and the program

runs with task 0, and the task number has no priority.

- If no task number is set for the files in the entire project, when downloading to the controller, the system prompts the following message WARN: no program set autorun

## 5.2. PC Upper-Computer Program Application

The controller supports development under various operating systems such as windows, linux, Mac, Android, and wince, and provides dll libraries in various environments such as vc, c#, vb.net, and labview, as shown in the figure below. PC software programming refers to "ZMotion PC Function Library Programming Manual".



The program developed using the PC software cannot be downloaded to the controller, and it is connected to the controller through the dll dynamic library. The dll library needs to be added to the header file and declared during development.

The c++ project development process in VS is as follows:

Step	Operations	Display Interface
1	Open VS, click "File" – "New" – "Project".	<p>The screenshot shows the Microsoft Visual Studio interface with the 'File' menu open. The 'New' option is selected, and the 'Project...' sub-option is highlighted. The keyboard shortcuts for 'Project...' (Ctrl+Shift+N) and 'File...' (Ctrl+N) are visible.</p>

<p>2</p>	<p>Select development language as "Visual C++" and the select program type as "MFC application type".</p>	
<p>3</p>	<p>Select "Based on basic box", click "next" or "finish".</p>	
<p>4</p>	<p>Find C++ function library provided by manufacturer. Routine is below (64-bit library)</p>	
<p>5 Copy all DLL related library files under the above path to the newly created project.</p>		
<p>6</p>	<p>Add a static library and related header files to the project. Static library: zauxdll.lib,</p>	<p>1) Right-click the header file first, and then select: "Add" → "Existing"</p> 

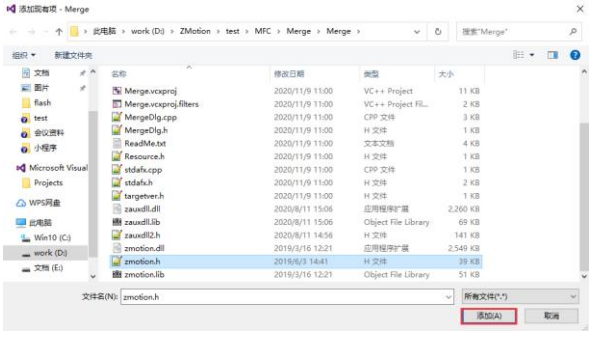
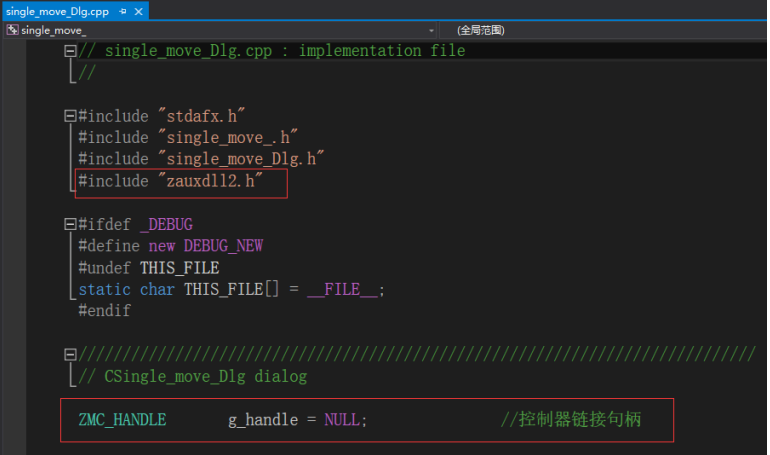
	<p>zmotion.lib</p> <p>Related header files: zauxdll2.h, zmotion.h</p>	<p>Item".</p> <p>2) Add static libraries and related header files in sequence in the pop-up window.</p>	
<p>7</p>	<p>Declare the relevant header files and define the controller connection handle, so far the project is newly created.</p>		

## Chapter VI Run and Maintain

The correct operation and maintenance of the device can not only guarantee and extend the life cycle of the equipment itself, but also take technical management measures according to the pre-specified plan or the corresponding technical conditions to prevent equipment performance degradation or reduce the probability of equipment failure.

### 6.1. Regular Inspection and Maintenance

The working environment has an impact on the device. Therefore, it is usually inspected regularly based on the inspection cycle of 6 months to 1 year. The inspection cycle of the device can be appropriately adjusted according to the surrounding environment to make it work within the specified standard environment.

Check item	Check content	Inspection standards
power supply	Check whether the voltage is rated	DC 24V ( -5%~5% )
surroundings	Whether the ambient temperature is within the specified range (when installed in the cabinet, the temperature inside the cabinet is the ambient temperature)	-10°C - 55°C
	Whether the ambient humidity is within the specified range (when installed in the cabinet, the humidity in the cabinet is the ambient humidity)	10%-95% non-condensing
	Is there direct sunlight	No
	With or without droplets of water, oil, chemicals, etc.	No
	Whether there is dust, salt, iron filings, dirt	No
	Whether there is corrosive gas	No
	Whether there are flammable and explosive gases or articles	No

	Whether the device is subjected to vibration or shock	Should be within the range of vibration resistance and impact resistance
	Is the heat dissipation good	Keep good ventilation and heat dissipation
Installation and Wiring Status	Whether the basic unit and the expansion unit are installed firmly	The mounting screws should be tightened without loosening
	Whether the connecting cables of the basic unit and the expansion unit are fully inserted	The connection cable cannot be loosened
	Are the screws of the external wiring loose	Screws should be tightened without loosening
	Whether the cable is damaged, aged, cracked	The cable must not have any abnormal appearance

## 6.2. Common Problems

Problems	Suggestions
Motor does not rotate.	<ol style="list-style-type: none"> <li>1. Check whether the ATYPE of the controller is correct.</li> <li>2. Check whether hardware position limit, software position limit, alarm signal work, and whether axis states are normal.</li> <li>3. Check whether motor is enabled successfully.</li> <li>4. Confirm whether pulse amount UNITS and speed values are suitable. If there is the encoder feedback, check whether MPOS changes.</li> <li>5. Check whether pulse mode and pulse mode of drive are matched.</li> <li>6. Check whether alarm is produced on motion controller station or drive station.</li> <li>7. Check whether the wiring is correct.</li> <li>8. Confirm whether controller sends pulses normally.</li> </ol>
The position limit signal is	<ol style="list-style-type: none"> <li>1. Check whether the limit sensor is working normally,</li> </ol>



invalid.	<p>and whether the "input" view can watch the signal change of the limit sensor.</p> <ol style="list-style-type: none"> <li>2. Check whether the mapping of the limit switch is correct.</li> <li>3. Check whether the limit sensor is connected to the common terminal of the controller.</li> </ol>
No signal comes to the input.	<ol style="list-style-type: none"> <li>1. Check whether the limit sensor is working normally, and whether the "input" view can watch the signal change of the limit sensor.</li> <li>2. Check whether the mapping of the limit switch is correct.</li> <li>3. Check whether the limit sensor is connected to the common terminal of the controller.</li> </ol>
The output does not work.	<ol style="list-style-type: none"> <li>1. Check whether IO power is needed.</li> <li>2. Check whether the output number matches the ID of the IO board.</li> </ol>
POWER led is ON, RUN led is OFF.	<ol style="list-style-type: none"> <li>1. Check whether the power of the power supply is sufficient. At this time, it is best to supply power to the controller alone, and restart the controller after adjustment.</li> <li>2. Check whether the ALM light flickers regularly (hardware problem).</li> </ol>
RUN led is ON, ALM led is ON.	<ol style="list-style-type: none"> <li>1. Program running error, please check ZDevelop error code, and check application program.</li> </ol>
Fail to connect controller to PC through serial port.	<ol style="list-style-type: none"> <li>1. Check whether the serial port parameters are modified by the running program, you can check all the current serial port configurations through ?*SETCOM.</li> <li>2. Check whether the serial port parameters of the PC match the controller.</li> <li>3. Open the device manager and check whether the serial driver of the PC is normal.</li> </ol>
CAN expansion module cannot be connected.	<ol style="list-style-type: none"> <li>1. Check the CAN wiring and power supply circuit, whether the 120 ohm resistor is installed at both ends.</li> </ol>

	<ol style="list-style-type: none"> <li>2. Check the master-slave configuration, communication speed configuration, etc.</li> <li>3. Check the DIP switch to see if there are multiple expansion modules with the same ID.</li> <li>4. Use twisted-pair cables, ground the shielding layer, and use dual power supplies for severe interference (the main power supply of the expansion module and the IO power supply are separately powered)</li> </ol>
<p>Fail to connect controller to PC through net port.</p>	<ol style="list-style-type: none"> <li>1. Check IP address of PC, it needs to be at the same segment with controller IP address.</li> <li>2. Check controller IP address, it can be checked and captured after connection through serial port.</li> <li>3. When net port led is off, please check wiring.</li> <li>4. Check whether controller power led POWER and running indicator led RUN are ON normally.</li> <li>5. Check whether the cable is good quality, change one better cable to try again.</li> <li>6. Check whether controller IP conflicts with other devices.</li> <li>7. Check whether controller net port channel ETH are all occupied by other devices, disconnect to other devices, then try again.</li> <li>8. When there are multiple net cards, don't use other net cards, or change one computer to connect again.</li> <li>9. Check PC firewall setting.</li> <li>10. Use "Packet Internet Groper" tool (Ping), check whether controller can be Ping, if it can't, please check physical interface or net cable.</li> <li>11. Check IP address and MAC address through arp-a.</li> </ol>